

ICC-ES Evaluation Report**ESR-1344**

Reissued December 1, 2013

This report is subject to renewal December 1, 2015.

www.icc-es.org | (800) 423-6587 | (562) 699-0543

A Subsidiary of the International Code Council®

**DIVISION: 06 00 00—WOOD, PLASTICS AND
COMPOSITES**
**Section: 06 05 23—Wood, Plastic, and Composite
Fastenings**

REPORT HOLDER:

COMMINS MANUFACTURING, INC.
960 B GUARD STREET
FRIDAY HARBOR, WASHINGTON 98250
(360) 378-9484
www.comminsmfg.com

EVALUATION SUBJECT:

**AT AUTOMATIC TAKE-UP™ SHRINKAGE
COMPENSATOR**

1.0 EVALUATION SCOPE**Compliance with the following codes:**2012 and 2009 *International Building Code*® (IBC)**Property evaluated:**

Structural

2.0 USES

The AT Automatic Take-Up™ Shrinkage Compensator device is used to remove slack in hold-down systems due to settlement or wood shrinkage.

3.0 DESCRIPTION**3.1 General:**

The AT Automatic Take-Up™ Shrinkage Compensator is a self-expanding washer used in connections of shearwall hold-down connectors or tension tie connectors incorporating threaded rods or threaded anchor bolts. The shrinkage compensator is available with either a steel body or an aluminum body. The devices automatically expand, axially, to eliminate any gaps between the bearing surface and the nut on the threaded rod that occur due to settlement or wood shrinkage. Sizes, rod diameters, dimensions, maximum expansion (shrinkage compensation capacity), and capacities are listed in Table 1. See Figure 1 for a typical installation.

3.2 Materials:

The outer (body) component of the device has internal threads. The inner (stud) component of the device has matching external threads. For the devices with a body and stud made of steel, the inner components are manufactured from ASTM A108-99 Grade 12L14 steel

with minimum yield and tensile strengths of 65 and 75 ksi (448 and 517 kPa), respectively. The outer components are manufactured from either ASTM A108 Grade 12L14 steel with minimum yield and tensile strengths of 65 and 75 ksi (448 and 517 kPa), respectively, or DOM 1020/1028 steel tubing with minimum yield and tensile strengths of 84 and 95 ksi (579 and 657 kPa), respectively, for the AT75-2.5, and 71 and 80 ksi (490 and 551 kPa), respectively, for all the other AT devices. A finish and lubricant, specified in the approved quality control manual, is applied to the outer and inner components to resist corrosion. The devices with a body and stud made of aluminum are manufactured from ASTM B221-12 6061-T6511 aluminum. All the devices have an internal spring manufactured from 17-7 PH stainless steel, per SAE AMS 5678, or high-carbon steel music wire per ASTM A228-02.

4.0 DESIGN AND INSTALLATION**4.1 Design and Allowable Loads:**

The allowable compression loads for the AT Automatic Take-Up™ Shrinkage Compensator designed under allowable stress design are as shown in Table 1. The devices are to be used where the expected shrinkage does not exceed the expansion limit of the devices. Two devices may be used in-line where the expected shrinkage exceeds the expansion limit of one device.

When the devices are used in continuous rod systems that resist light-frame shear wall overturning forces, calculations must be submitted to the code official confirming that the total vertical displacement, which would include steel rod elongation and the shrinkage compensating device deflection, is less than or equal to 0.20-inch (5 mm) for each story, or between restraints, whichever is more restrictive, using allowable stress design (ASD). Shear wall drift limit calculations must consider the 0.20-inch (5 mm) vertical displacement limit. This 0.20-inch (5 mm) vertical displacement limit may be exceeded when it can be demonstrated that the shear wall story drift limit and the deformation compatibility requirements of IBC Section 1604.4 are met when considering all sources of vertical displacement.

4.2 Installation:

The AT Automatic Take-Up™ Shrinkage Compensator must only be used where there is sufficient clearance along the sides of the device to permit the device to expand. The device must be installed over the hold-down or bearing plate with the threaded rod through the axial center of the device. An SAE flat washer and steel nut must be installed on the threaded rod and tightened prior

to activation of the device. Activation occurs by removal of a factory-inserted screw from the side of the device. The continuous tie-down system in which the AT Automatic Take-Up™ Shrinkage Compensator is used must be installed plumb, such that the offset angle between the top of the floor and the bottom of the top plates or bridge block above does not exceed 1.33 degrees (steel) or 2 degrees (aluminum) from vertical.

5.0 CONDITIONS OF USE

The AT Automatic Take-Up™ Shrinkage Compensator described in this report complies with, or is a suitable alternative to what is specified in, those codes listed in Section 1.0 subject to the following conditions:

5.1 Calculations, demonstrating that the applied loads do not exceed the allowable loads and that the expected shrinkage does not exceed the expansion limits of the device, must be submitted to the code official for approval. The calculations must be prepared by a registered design professional where required by the statutes of the jurisdiction in which the project is to be constructed.

- 5.2** The Commins AT Automatic Take-Up™ Shrinkage Compensator must be limited to installations in dry, interior locations.
- 5.3** No increase in allowable stresses or loads for duration of load are permitted for the Commins AT Automatic Take-Up™ Shrinkage Compensator.
- 5.4** The AT Automatic Take-Up™ Shrinkage Compensator must not be used to support dead load other than its own weight.

6.0 EVIDENCE SUBMITTED

Data in accordance with ICC-ES Acceptance Criteria for Shrinkage Compensating Devices (AC316), dated June 2012.

7.0 IDENTIFICATION

Each AT Automatic Take-Up™ Shrinkage Compensator must bear a label on the device or on the packaging indicating the manufacturer's name (Commins Manufacturing, Inc.), the model number, and the evaluation report number (ESR-1344).

TABLE 1—AT AUTOMATIC TAKE-UP™ SHRINKAGE COMPENSATOR DESCRIPTION AND ALLOWABLE LOADS¹

MODEL NO.	INSIDE DIAMETER (inches)	OUTSIDE DIAMETER (inches)	DEVICE LENGTH (inches)		MAXIMUM EXPANSION (inches)	SEATING INCREMENT ² Δ _R (inches)	ALLOWABLE AXIAL COMPRESSION LOAD P _A (pounds)	DEFLECTION AT ALLOWABLE LOAD ² Δ _A (inch)
			Minimum	Maximum				
Aluminum								
AT 4A-1.5	1/2	1 1/2	3.0	4.5	1.50	0.000	6,450	0.011
AT 4A-2.5	1/2	1 1/2	4.06	6.56	2.50	0.000	6,450	0.011
AT 6A-1.5	3/4	2 1/8	3.19	4.69	1.50	0.000	10,550	0.011
AT 6A-2.5	3/4	2 1/8	4.19	6.69	2.50	0.000	10,550	0.011
Steel								
AT 75	3/4	2	2.80	3.90	1.10	0.002	16,450	0.024
AT 75-2.5	3/4	2	4.0	6.5	2.50	0.002	15,200	0.021
AT 100	1	2 1/4	2.90	4.00	1.10	0.002	25,300	0.032
AT 125	1 1/4	2 3/4	2.86	3.98	1.10	0.002	34,500	0.016

For **SI**: 1 inch = 25.4 mm, 1 pound = 4.45 N.

¹Listed values are for the AT Automatic Take-Up™ Shrinkage Compensator only. All other components in the system must be designed in accordance with the applicable code.

²The device average travel and seating increment, Δ_R, and deflection at allowable load, Δ_A, are additive and describe the total movement of the device at allowable load, Δ_T. For design loads, P_D, less than the allowable load, P_A, the total movement of the device, Δ_T, is calculated as follows: Δ_T = Δ_R + Δ_A(P_D/P_A).

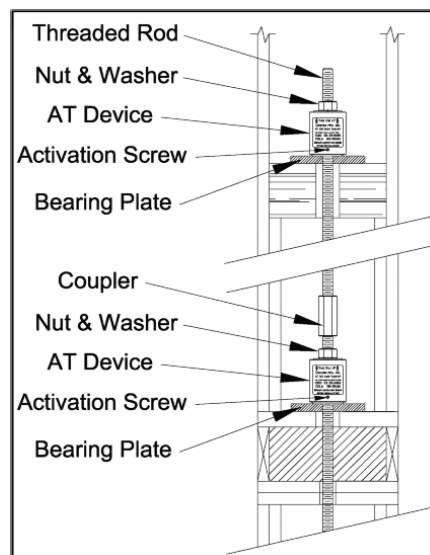

FIGURE 1—TYPICAL INSTALLATION

ICC-ES Evaluation Report**ESR-1344 CBC Supplement**

Reissued December 1, 2013

This report is subject to renewal December 1, 2015.www.icc-es.org | (800) 423-6587 | (562) 699-0543

A Subsidiary of the International Code Council®

DIVISION: 06 00 00—WOOD, PLASTIC AND COMPOSITES
Section: 06 05 23—Wood, Plastic, and Composite Fastenings**REPORT HOLDER:****COMMINS MANUFACTURING, INC.**
960 B GUARD STREET
FRIDAY HARBOR, WASHINGTON 98250
(360) 378-9484
www.comminsmfg.com**EVALUATION SUBJECT:****AT AUTOMATIC TAKE-UP™ SHRINKAGE COMPENSATOR****1.0 REPORT PURPOSE AND SCOPE****Purpose:**

The purpose of this evaluation report supplement is to indicate that the AT Automatic Take-Up™ Shrinkage Compensator, recognized in ICC-ES master report ESR-1344, has also been evaluated for compliance with Chapters 16, 16A, 17, 17A and 23 of the code noted below.

Applicable code edition:2010 *California Building Code* (CBC)**2.0 CONCLUSIONS**

The AT Automatic Take-Up™ Shrinkage Compensator, described in Sections 2.0 through 7.0 of the master evaluation report ESR-1344, complies with CBC Chapters 16, 16A, 17, 17A and 23, provided the design and installation are in accordance with the *International Building Code*® (IBC) provisions noted in the master report and the additional requirements of with CBC Chapters 16, 16A, 17, 17A and 23, as applicable.

This supplement expires concurrently with the master report reissued on December 1, 2013.