



## EVALUATION SUBJECT: CONNECTORS FOR COLD-FORMED STEEL CURTAIN-WALL CONSTRUCTION

### REPORT HOLDER:

**Simpson Strong-Tie Company Inc.**  
5956 West Las Positas Boulevard  
Pleasanton, California 94588  
(800) 999-5099  
[www.strongtie.com](http://www.strongtie.com)

CSI Division: 05 – METALS

CSI Section: 05 40 00 – Cold-Formed Metal Framing

### 1.0 SCOPE OF EVALUATION

#### 1.1 Compliance to the following codes & regulations:

- 2015 International Building Code® (2015 IBC)
- 2012 International Building Code® (2012 IBC)
- 2009 International Building Code® (2009 IBC)
- 2006 International Building Code® (2006 IBC)

#### 1.2 Evaluated in accordance with:

- ICC-ES AC261, approved October 2011, editorially revised August 2013
- \* • ~~ICC-ES AC70, approved February 2016~~

#### 1.3 Properties assessed:

- Structural

### 2.0 PRODUCT USE

Simpson Strong-Tie® connectors for cold-formed steel curtain-wall construction are used to connect cold-formed steel framing members to a supporting structural member, in conformance with IBC Sections [2210](#) and [2211](#).

### 3.0 PRODUCT DESCRIPTION

#### 3.1 Product Information

##### 3.1.1 MSCB/SCB Bypass Framing Slide-Clip Connector:

The MSCB/SCB slide-clip connectors are used to connect cold-formed steel framing to other structural members while allowing relative movement between the members. Applications include, but are not limited to, attachments between cold-formed steel studs of an exterior curtain-wall system and the primary building structural system. The MSCB and SCB connectors are formed from 68 mil (No.14 gauge), and from 54 mil (No. 16 gauge) thick steel, respectively. The connectors include three slots, except for the SCB43.5, which has two slots, for the installation of shouldered screws, described in Section 3.2.2 of this report, to attach the MSCB/SCB to the cold-formed steel member and allow relative movement.

“No-Equal” stamps mark the center of the slots to help ensure correct fastener placement. Pre-punched holes in the anchor leg facilitate attachment to a supporting member.

Model types, dimensions, fastener requirements, allowable loads, load directions, and installation details are shown in [Table 1A](#), [Table 1B](#) and [Figure 1](#) of this report.

##### 3.1.2 SSB Bypass Framing Slide-Clip Strut Connector:

The SSB strut connectors are used to connect cold-formed steel framing to other structural members while allowing relative movement between the members. Applications include, but are not limited to, attachments between cold-formed steel studs of an exterior curtain-wall system and the primary building structural system. The SSB connectors are formed from 54 mil (No. 16 gauge) thick steel. The connectors include three slots at each end for installation of shouldered screws, described in Section 3.2.2 of this report, to attach the SSB to the cold-formed steel member and allow relative movement. “No-Equal” stamps mark the center of the slots to help ensure correct fastener placement. Pre-punched holes along the entire length of the anchor leg facilitate attachment to a supporting member. Model types, dimensions, fastener requirements, allowable loads, load directions, and installation details are shown in [Table 2](#) and [Figure 2](#) of this report.

##### 3.1.3 SCW Head-of-Wall Slide-Clip Connector:

The SCW slide-clip connectors are used to connect cold-formed steel framing to other structural members while allowing relative movement between the members. Applications include, but are not limited to, attachments between the end of cold-formed steel studs of an exterior curtain-wall system and the primary building structural system. The SCW connectors are formed from 54 mil (No. 16 gauge) thick steel. The SCW3.25 connectors include two slots and the SCW5.5 connectors have three slots for installation of shouldered screws, described in Section 3.2.2 of this report, to attach the SCW to the cold-formed steel member and allow relative movement. “No-Equal” stamps mark the center of the slots to help ensure correct fastener placement. Pre-punched holes in the anchor leg facilitate attachment to a supporting member. Model types, dimensions, fastener requirements, allowable loads, load directions, and installation details are shown in [Table 3](#) and [Figure 3](#) of this report.

##### 3.1.4 FCB Bypass Framing Fixed-Clip Connector:

The FCB fixed-clip connectors are used to provide a fixed connection between cold-formed steel framing and other structural members. Applications include, but are not limited to, attachments between cold-formed steel studs of an exterior curtain-wall system and the primary building

The product described in this Uniform Evaluation Service (UES) Report has been evaluated as an alternative material, design or method of construction in order to satisfy and comply with the intent of the provision of the code, as noted in this report, and for at least equivalence to that prescribed in the code in quality, strength, effectiveness, fire resistance, durability and safety, as applicable, in accordance with IBC Section 104.11. This document shall only be reproduced in its entirety.

Copyright © 2017 by International Association of Plumbing and Mechanical Officials. All rights reserved. Printed in the United States. Ph: 1-877-4IESRPT • Fax: 909.472.4171 • web: [www.uniform-es.org](http://www.uniform-es.org) • 4755 East Philadelphia Street, Ontario, California 91761-2816 – USA





structural system. The FCB connectors are formed from 54 mil (No. 16 gauge) thick steel. The connectors include holes for installation of screws to attach the FCB to the cold-formed steel member. Round and triangle holes designate Min. and Max. fastener patterns, respectively. Pre-punched holes in the anchor leg facilitate attachment to a supporting member.

Model types, dimensions, fastener requirements, allowable loads, load directions, and installation details for the connectors and their attachment to the cold-formed steel member are shown in [Table 4A](#) and [Figure 4](#) of this report. Fastener requirements, allowable loads, load directions, and installation details for anchorage of the connectors to the supporting structural members are shown in [Table 4B](#) and [Figure 4](#) of this report.

**3.1.5 LSSC, SSC and MSSC Steel Stud Connector:** The SSC series connectors are utility clips used to provide connection between cold-formed steel (CFS) stud to CFS framing members and CFS stud to structural members.

The SSC series are available in three different mil (gauge) thicknesses and a variety of sizes. The LSSC, SSC and MSSC connectors are formed from 54 mil (No. 16 gauge), 68 mil (No. 14 gauge), and 97 mil (No. 12 gauge) steel, respectively.

The connectors include holes for installation screws to attach the Steel Stud Connectors to CFS members. Round and triangle holes designate Min. and Max. fastener patterns. Square holes are also provided, and can be combined with round and triangle holes for custom screw patterns per specification of the Designer. Pre-punched holes in the anchor leg facilitates attachment to a supporting member.

Model types, dimensions, fastener requirements, allowable loads, load directions, and installation details are shown in [Table 5](#) and [Figure 5](#) of this report.

\* **3.1.5.1** SSC series may be used in a variety of applications including By-Pass Framing, Header, Base-of-Jamb, Rafter, U-Channel Bridging, and Kneewall applications. Application types, model names, fastener requirements, allowable loads, load directions, and installation details are shown in Tables 5.1 to 5.6 and Figures 5.1 to 5.6, respectively.

The SSC connectors are used in U-Channel applications utilizing cold-formed steel 1 1/2-inch by 1/2-inch (38.1 mm x 12.7 mm) U-channel bridging members.

MSSC connectors used in Kneewall applications include a bearing plate, BP<sup>1/2-3</sup>, providing moment resistance at the base.

**3.1.6 SJC and MSJC Steel Joist Connector:** The SJC series connectors are utility clips used to provide connection between cold-formed steel (CFS) joist to CFS framing members and CFS joist to structural members. The SJC series are available in two different mil (gauge) thicknesses and sizes. The SJC and MSJC connectors are formed from 68 mil (No. 14 gauge), and 97 mil (No. 12 gauge) steel, respectively.

The connectors include holes for installation screws to attach the SJC and MSJC Connectors to CFS members. Round and triangle holes designate Min. and Max. fastener patterns. Square holes are also provided, and can be combined with round and triangle holes for custom screw patterns per specification of the Designer. Pre-punched holes in the anchor leg facilitate attachment to a supporting member.

Model types, dimensions, fastener requirements, allowable loads, load directions, and installation details are shown in [Table 6](#) and [Figure 6](#) of this report.

**3.1.6.1** SJC series connectors may be used in Kicker applications. Fastener requirements, allowable loads, load direction, and installation details are shown in Table 6.1 and Figure 6.1.

**3.1.7 LSFC and SFC Steel Framing Connector:** The SFC series connectors are utility clips used in light and moderate condition to provide connection between cold-formed steel (CFS) stud to CFS stud framing members and CFS stud to structural members.

The SFC series are available in two different mil (gauge) thicknesses and three sizes. The LSFC and SFC connectors are formed from 43 mil (No.18 gauge) and 54 mil (No. 16 gauge) steel, respectively.

The connectors include holes for installation screws to attach the Steel Framing Connectors to CFS members. Round and triangle holes designate Min. and Max. fastener patterns.

Model types, dimensions, fastener requirements, allowable loads, load directions, and installation details are shown in [Table 7](#) and [Figure 7](#) of this report.

**3.1.7.1** SFC series connectors may be used in U-Channel Bridging applications utilizing cold-formed steel 1 1/2-inch by 1/2-inch (38.1 mm x 12.7 mm) U-channel bridging members. Fastener requirements, allowable loads, load direction, and installation details are shown in Table 7.1 and Figure 7.1.

**3.1.8 RCKW and RCKWS rigid knee wall connector:** The RCKW series connectors are used to provide a moment connection between cold-formed steel framing and other structural members. Applications include, but are



not limited to, attachments between cold-formed steel studs of exterior kneewalls, parapets, handrail and guardrail systems, as well as interior partial-height walls to the primary building structural system.

The RCKWS is a stiffener that nests into the RCKW clip. The screw holes and anchor holes in the stiffener line-up with those in the RCKW clip. The RCKW and RCKWS connectors are formed from 171-mil-thick (No.7 gauge) steel. The connectors include holes for installation of screws to attach the RCKW to the cold-formed steel member. Pre-punched holes in the anchor leg facilitate attachment to a supporting member.

Model types, dimensions, fastener requirements, allowable loads, load directions, and installation details for the connectors and their attachment to the cold-formed steel member are shown in Table 8 and Figure 8 of this report.

### 3.2 Materials

#### 3.2.1 Connectors Material

**MSCB, SCB, SSB, SCW, and FCB Connectors:** The Slide-Clip and Fixed-Clip connectors described in sections 3.1.1, 3.1.2, 3.1.3 and 3.1.4 are manufactured from steel conforming with [ASTM A653](#), SS Grade 40 with a minimum yield strength of 40,000 psi (275 MPa) and a minimum tensile strength of 55,000 psi (380 MPa).

**SSC, SJC and SFC Series Connectors:** The Utility Clip connectors described in sections 3.1.5, 3.1.6 and 3.1.7 of this report are manufactured from steel conforming with ASTM A653, SS, Grade 50 with a minimum yield strength of 50,000 psi (345 MPa) and a minimum tensile strength of 65,000 psi (448 MPa).

**RCKW and RCKWS Series Connectors:** The Rigid Kneewall Connectors described in Section 3.1.8 of this report are manufactured from steel conforming with ASTM A653, SS, Grade 33 with a minimum yield strength of 33,000 psi (228 MPa) and a minimum tensile strength of 45,000 psi (310 MPa).

The connectors described in this report have a minimum base metal thickness as shown in the table below and a minimum of G90 zinc coating specification in accordance with ASTM A653.

Model No.	Nominal Thickness mil (gauge)	Min. Base Metal Thickness (inch)
MSCB	68 (14)	0.070
SCB	54 (16)	0.057
SSB	54 (16)	0.057
SCW	54 (16)	0.057
FCB	54 (16)	0.057
LSSC	54 (16)	0.057
SSC	68 (14)	0.070
MSSC	97 (12)	0.099
SJC	68 (14)	0.070
MSJC	97 (12)	0.099
LSFC	43 (18)	0.046
SFC	54 (16)	0.057
RCKW	171(7)	0.173
RCKWS	171(7)	0.173

For SI 1 mil=0.0254 mm, 1 inch = 2.54 mm

**3.2.2 #14 Shouldered Screws:** The proprietary #14 shouldered screws used in the slots of the MSCB/SCB, SSB, and SCW connectors as described in this report shall conform with IAPMO UES [UR-242](#). MSCB connectors shall use #14 shouldered screw model number XLSH34B1414, which has a washer diameter of 0.625 inch (15.88 mm). All other connectors, SCB, SSB, and SCW, can use either #14 shouldered screw model number XLSH34B1414 or XSH34B1414. The later shouldered screw model has a washer diameter of 0.553 inch (14.05 mm).

**3.2.3 Self-Drilling Screws:** Screws used to attach the connectors recognized in this report shall be self-drilling tapping screws in compliance with [ASTM C1513](#) or listed in an IAPMO UES or other approved and accredited evaluation service agency evaluation report. Screw length shall be selected based on the total thickness of materials to be joined such that the screws extend through the steel connection a minimum of 3 exposed threads.

**#12 Self-Drilling Screws:** Screws used in round and triangle holes to attach the FCB connectors to the supported members and to attach the MSCB/SCB, SSB, SCW, and FCB connectors to the supporting structure shall be #12 self-drilling tapping screws.

RCKW and RCKWS use #12 screws to attach clips to the supported members.

Screws shall have a minimum nominal diameter of 0.216 inch (5.5 mm) with 14 threads per inch, and a minimum hex washer head integral washer diameter of 0.398 inch (10.1 mm). Screws shall also have a minimum allowable fastener shear strength, Pss/Ω, of 840 lbs. (3737 N), and a minimum allowable fastener tensile strength, Pts/Ω, of 845



lbs (3759 N).

**#10 Self-Drilling Screws:** Screws used in round, triangle, and square holes to attach the Utility Clip, SSC, SJC and SFC connectors, to the supported members shall be #10 self-drilling tapping screws.

Screws shall have a minimum nominal diameter of 0.190 inch (4.8 mm) with 16 threads per inch, and a minimum hex washer head integral washer diameter of 0.375 inch (9.5 mm). Screws shall also have a minimum allowable fastener shear strength,  $P_{ss}/\Omega$ , of 540 lbs (2402 N), and a minimum allowable fastener tensile strength,  $P_{ts}/\Omega$ , of 820 lbs (3648 N).

**3.2.4 Cold-Formed Steel Framing:** Cold-formed steel framing members to which the connectors recognized in this report are attached shall be manufactured from materials in compliance with the American Iron and Steel Institute (AISI) *North American Specification for the Design of Cold-Formed Steel Structural Members* ([AISI S100](#)). Loads provided in this report are based on the following material properties for the cold-formed members:

MEMBER THICKNESS DESIGNATION	DESIGN THICKNESS (in.)	MINIMUM YIELD STRESS (psi)	MINIMUM TENSILE STRESS (psi)
33 mil (20 ga.)	0.0346	33,000	45,000
43 mil (18 ga.)	0.0451	33,000	45,000
54 mil (16 ga.)	0.0566	50,000	65,000
68 mil (14 ga.)	0.0713	50,000	65,000
97 mil (12 ga.)	0.1017	50,000	65,000
118 mil (10 ga.)	0.1242	50,000	65,000

For SI 1 mil=0.0254 mm, 1 inch = 2.54 mm, 1 psi =0.006895 MPa

Use of connectors in this report with materials not conforming to the requirements of this section is outside the scope of this report.

**U-Channel Cold-Formed Steel Members:** Cold-formed steel 1 1/2-inch by 1/2-inch (38.1 mm x 12.7 mm) U-channel bridging members must have a minimum base metal thickness of 0.0566 inch with a minimum yield strength of 33,000 psi (227 MPa) and a minimum tensile strength of 45,000 psi (310 MPa).

**3.2.5 Structural Steel Framing:** The tabulated loads shown in this report are for connectors attached to structural steel members a minimum of 3/16 inch (4.8 mm) thick, with a minimum yield stress of 36,000 psi (250 MPa) and a minimum tensile stress of 58,000 psi (400 MPa). Use of connectors in this report with materials not conforming to the requirements of this section is outside the scope of this report. Sections 4.1.2 and 4.1.3 of this report describe anchorage to alternate materials.

**3.2.6 Weld Filler Metal:** Tabulated loads in this report for connectors attached to supporting structural steel by welding are based on minimum E70XX electrodes.

**3.2.7 Bearing Plate:** Bearing plate BP<sup>1/2-3</sup>, used to anchor legs of MSSC connectors must have a minimum base metal thickness of 0.0229 inch with a minimum yield strength of 33,000 psi (227 MPa) and a minimum tensile strength of 52,000 psi (360 MPa).

**3.2.8 Anchor Threaded Rods:** As a minimum, anchor threaded steel rods must comply with ASTM F1554 Grade 36 or ASTM A307.

**3.2.9 PDPAT Powder Actuated Fasteners:** Simpson Strong-Tie® PDPAT powder actuated Tophat fasteners recognized in ICC-ES ESR-2138 may be used to anchor SCB, MSCB, FCB, SSC, and MSSC connectors, as an alternate to anchoring using self-drilling anchor screws or welds described in Sections 3.2.3 and 3.2.6, respectively.

## 4.0 DESIGN AND INSTALLATION

### 4.1 Design

**4.1.1 General:** The tabulated loads shown in this report are for use with Allowable Stress Design (ASD) and are applicable to both the basic load combinations contained in IBC Section [1605.3.1](#) and the alternative load combinations in IBC Section [1605.3.2](#). Allowable load increases for wind or seismic loads are not permitted.

Allowable loads are presented in [Tables 1](#) to 7 of this report and are based on the least of the following values:

- The average test load at which 1/8 inch (3.2 mm) relative movement occurs between the supported cold-formed steel member and the supporting structural member.
- The average ultimate test load divided by a safety factor,  $\Omega$ , determined in accordance with AISI S100 Chapter F.
- Allowable load for screws used to attach the connectors to the supported cold-formed steel member:
  - For the MSCB/SCB, SSB, and SCW slide-clip connectors, the allowable shear for the #14 shouldered screws based on IAPMO UES [ER-242](#).
  - For the FCB fixed-clip connectors, the allowable load for #12 self-drilling screws calculated in accordance with Section E4 of AISI S100.
  - For the Utility Clip SSC, SJC and SFC connectors, the allowable load for #10 self-drilling screws calculated in accordance with Section E4 of AISI S100.



4. Allowable load for welds and screws used to anchor the connectors to the supporting structure, calculated in accordance with Section E2 and E4, respectively, of AISI S100, and for powder-actuated fasteners tested in accordance with ASTM E1190.

Allowable loads tabulated for connectors attached to 54 mil (No. 16 gage) thick members are also applicable to thicker members, up to a maximum thickness of 118 mil (No. 10 gage), provided the steel has a yield strength and tensile strength meeting the requirements for 54 mil (16 gage) thick material outlined in Section 3.2.4.

**4.1.2 MSCB/SCB, SSB, and SCW Slide-Clip Connectors:** Allowable loads are tabulated for the MSCB/SCB, SSB, and SCW connectors in [Tables 1A, 2, and 3](#) of this report, respectively. Tabulated loads require use of the proprietary #14 shouldered screws supplied with the connectors. For anchorage options shown in the tables and accompanying figures, attachment of the connectors to the supporting structure has been considered and no further design of the connection is required. Table 1B gives alternate anchorage options for SCB and MSCB connectors using PDPAT fasteners. For alternate anchorage options, the connection capacity will be the least of the tabulated value and the calculated allowable strength for the anchorage. The allowable strength of alternate anchorage options shall be calculated by a registered design professional and submitted to the code official. When installed as described in this report, the connectors will provide 1 inch (25.4 mm) of relative movement in each direction, parallel with the length of the slots.

**4.1.3 FCB Fixed-Clip Connectors:** Allowable loads are tabulated for the FCB connectors in [Tables 4A and 4B](#) of this report. The allowable strength will be the least value of the connector strength from [Table 4A](#) of this report and the anchorage strength from [Table 4B](#) of this report. For anchorage options shown in the tables, attachment of the connectors to the supporting structure has been considered and no further design of the connection is required. Table 4B gives alternate anchorage options for FCB connectors using PDPAT fasteners. For alternate anchorage options, the connection capacity will be the least of the tabulated connector value in [Table 4A](#) of this report and the calculated allowable strength for the anchorage. The allowable strength of alternate anchorage options shall be calculated by a registered design professional and submitted to the building official.

**4.1.4 SSC, SJC and SFC series Connectors:** Allowable loads are tabulated for the SSC connectors in [Tables 5, 5.1, 5.2, 5.3, 5.4, 5.5, 5.6 and 8](#). For SJC connectors, the allowable loads are tabulated in [Tables 6 and 6.1](#). For SFC connectors, the allowable loads are tabulated in [Tables 7 and 7.1](#).

Tabulated loads require use of the connectors attached to the minimum cold-formed steel framing members as designated in the connector tables and the screw patterns as shown in [Figures 5, 5.1, 5.2, 5.3, 5.4, 5.5, 5.6, 6, 6.1, 7 and 7.1](#).

For alternate framing member or screw pattern options, the connection capacity shall not exceed the Maximum Connector Load column tabulated in [Tables 5, 6, and 7](#). The allowable strength of alternate design shall be calculated by a registered design professional and submitted to the building official.

Table 5.1 includes alternate anchorage options for SCC series connectors using PDPAT fasteners. For alternate anchorage options, the connection capacity will be the least of the tabulated connector value in Table 5.1 of this report and the calculated allowable strength for the anchorage. The allowable strength of alternate anchorage options shall be calculated by a registered design professional and submitted to the building official.

Tabulated Allowable Stress Design (ASD) loads for U-Channel Bridging connectors SSC4.25 and SFC4.25 in this report are based on the average ultimate test load divided by a safety factor,  $\Omega$ , determined in accordance with AISI S100, Chapter F. For the design of axially loaded studs, the tabulated brace stiffness shall also be considered in accordance with the stiffness requirements given in Section D3.3 of AISI S100. The tabulated brace stiffness is based on 10 percent of nominal axial load. Allowable torsional moment, brace strength, and brace stiffness tabulated in [Table 5.5 and Table 7.1](#) of this report are for use with Sections D3.2.1 and D3.3 of AISI S100.

Tabulated anchor tension at allowable moment in [Table 5.6](#) for Kneewall MSSCKW connectors in this report are based on AISC Steel Design Guide 1, Section 3.4 - Design of Column Base Plates with Large Moments. The minimum concrete compression strength,  $f'_c$  is 3000 psi and the concrete bearing limit is based on  $(A_1/A_2)^{0.5} = 2$ . Where  $A_1$  is the connector bearing area and  $A_2$  is area of the concrete supporting surface. Reduce moment and anchor tension as required if concrete bearing ratio is less than 2.

**4.1.5 RCKW and RCKWS Series Connectors:** Allowable loads are tabulated for the RCKW and RCKWS Series Connectors in [Table 8](#).

Tabulated loads require use of the connectors attached to the minimum cold-formed steel framing members as designated in the connector tables and the screw patterns as shown in [Figure 8](#).

The tabulated Assembly Rotational Stiffness is based on wall deflection at allowable load in a 38-inch kneewall height. In addition to Assembly Rotational Stiffness, [Table 8](#) also provides values for Connector Rotational Stiffness,



which allows engineers to perform deflection calculations for assemblies of any wall height.

Tabulated anchor tension at allowable moment in Table 8 for RCKW connectors in this report is based on AISC Steel Design Guide 1, Section 3.4 - Design of Column Base Plates with Large Moments. The tabulated values are for minimum concrete compressive strength  $f'_c$ , of 3000 psi and 4000 psi. The concrete bearing limit is based on  $(A1/A2)^{0.5} = 2$ . Where A1 is the connector bearing area and A2 is an area of the concrete supporting surface. Reduce moment and anchor tension as required if concrete bearing ratio is less than 2.

For alternate framing member or screw pattern options, the allowable strength of alternate design shall be calculated by a registered design professional and submitted to the building official.

#### 4.1.6 Cold-Formed and Structural Steel Members:

Design of the cold-formed and structural steel members to which the connectors described in this report are attached is outside the scope of this report. The design of these members shall be performed by a registered design professional and submitted to the building official. A design professional shall verify the adequacy of the supported framing member. A design professional shall also evaluate penetrations, notches, and other conditions that may affect the performance of the connectors and determine the required clear distance between these conditions and the connectors. Connectors do not replace lateral or stability bracing of the supported members; design of bracing is the responsibility of the design professional. A designer shall also verify adequate strength and stability of the supporting structure to resist loads imposed by the connectors.

**4.2 Installation:** Installation of the connectors covered in this report shall be in accordance with the manufacturer's published installation instructions, this evaluation report, and the codes listed in Section 1.1 of this report.

Figures 1, 2, and 3 of this report provide installation details, including fastener placement, clearances, and required fastener edge distances, for the MSCB/SCB, SSB, and SCW connectors. The connectors shall be attached to the supported cold-formed steel member using the provided #14 shouldered screws. The specified number of screws shall be installed, with no more than one screw in a slot. Screws shall be centered in the slots by installing them adjacent to the "No-Equal" stamp on the connector. When the connectors are used with two shouldered screws, placement shall conform to the requirements contained in the footnotes of the appropriate table.

Figure 4 of this report provides installation details, including fastener placement, clearances, and required fastener edge distances for the FCB connectors. The

"Min." and "Max." fastener patterns require installation of the designated quantity of screws that conform with Section 3.2.3 of this report in the outstanding leg of the connector, attaching to the supported cold-formed member. In order to obtain the allowable loads tabulated for the "Min." fastener pattern, a screw shall be placed in each of the pre-punched round holes. To obtain loads listed for the "Max." fastener pattern, a screw shall be placed in each of the pre-punched round and triangle holes.

Figures 5, 6, and 7 provide installation details, including fastener placement, and required fastener edge distances for the SSC, SJC and SFC series connectors, respectively. The "Min." and "Max." fastener patterns require installation of the designated quantity of screws that conform with Section 3.2.3 of this report attaching to the supported cold-formed members. In order to obtain the allowable loads tabulated for the "Min." fastener pattern, a screw shall be placed in each of the pre-punched round holes. To obtain loads listed for the "Max." fastener pattern, a screw shall be placed in each of the pre-punched round and triangle holes.

For SSC series, to obtain loads listed for the "Outer" fastener pattern, refer to details labeled "Outer fastener Pattern" in Figure 5.

For SJC series, to obtain loads listed for the "Inner" fastener pattern, refer to details labeled "Inner Fastener Pattern" in Figure 6.

For Utility Clip connectors in various applications, refer to details shown in Figures 5.1 to 5.6, 6.1 and 7.1 for fastener pattern.

For connectors anchored to the supporting member using welds, welding shall be in compliance with American Welding Society *Structural Welding Code – Sheet Steel* (AWS D1.3). The throat size of the completed weld shall be equal to or greater than the base metal thickness for the connector listed in Section 3.2.1 of this report. Proper welding procedures and precautions for harmful fumes produced when welding galvanized steel shall be followed.

Figure 8 provides installation details and fastener pattern for RCKW and RCKWS.

For connectors anchored using PDPAT fasteners, the anchors shall be installed in accordance with the requirements of ESR-2138 and the manufacturer's installation instructions. The supporting steel shall be nominally 3/16 inch thick. A minimum distance of 1/2 inch shall be maintained between the fastener and the edge of the supporting steel.

## 5.0 LIMITATIONS

The Simpson Strong-Tie® products described in this report



are in compliance with, or are acceptable alternatives to what is specified in, those codes listed in Section 1.1 of this report subject to the following conditions:

**5.1** The connectors shall be manufactured, identified, and installed in accordance with the manufacturer’s published installation instructions and this report. A copy of the instructions shall be available at the jobsite at all times during installation. Where conflicts occur, the more restrictive shall govern.

**5.2** Calculations showing that design loads do not exceed the allowable loads contained in this report shall be submitted to the building official. The calculations shall be prepared by a registered design professional where required by the statutes of the jurisdiction in which the project will be constructed.

**5.3** Design of the attached cold-formed steel member and supporting structural steel member is outside the scope of this report and shall comply with the applicable code.

**5.4** The connectors shall be used in dry and non-corrosive environments only.

**5.5** Use of the PDPAT anchor has not been evaluated for seismic loading conditions.

## 6.0 SUBSTANTIATING DATA

Data in accordance with ICC-ES *Acceptance Criteria for Connectors Used With Cold-Formed Steel Structural Members* (AC261), approved October 2011, editorially revised August 2013, including test results from laboratories in compliance with [ISO/IEC 17025](http://www.iso.org/iso/17025).

## 7.0 IDENTIFICATION

The products described in this report are identified with a die-stamped label indicating the name of the manufacturer (Simpson Strong-Tie), the model number that corresponds with those listed in [Tables 1, 2, 3, 4A, 5, 5.1, 5.2, 5.3, 5.4, 5.5, 5.6, 6, 6.1, 7, 7.1 and 8](#), and the number of the index evaluation report ([ER-102](#)) which identifies products recognized in this report.

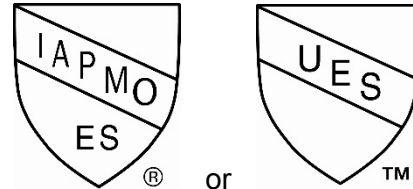

**IAPMO UES ER #238**

**Brian Gerber, P.E., S.E.**  
**Vice President, Technical Operations**  
**Uniform Evaluation Service**

**Richard Beck, PE, CBO, MCP**  
**Vice President, Uniform Evaluation Service**

**GP Russ Chaney**  
**CEO, The IAPMO Group**

For additional information about this evaluation report please visit [www.uniform-es.org](http://www.uniform-es.org) or email at [info@uniform-es.org](mailto:info@uniform-es.org)



**TABLE 1A – ALLOWABLE LOADS FOR MSCB/SCB SERIES CONNECTORS<sup>1</sup>**

Model No.	Connector Material Thickness mil (ga.)	L (in.)	No. of #14 Shouldered Screws In Slotted Holes	Allowable Load (lbs)							
				Supported Member Thickness							
				33 mil (20 ga.)		43 mil (18 ga.)		54 mil (16 ga.)		68 mil (14 ga.)	
F2	F3	F2	F3	F2	F3	F2	F3				
SCB43.5	54 (16)	3½	2	520	520	610	690	760	975	760	975
SCB45.5	54 (16)	5½	2 <sup>2</sup>	490	520	610	690	760	975	760	975
			3	675	675	895	1,000	990	1,260	990	1,260
MSCB45.5	68 (14)	5½	2 <sup>2</sup>	490	520	780	690	1,055	1,200	1,195	1,475
			3	675	675	1,070	1,000	1,220	1,540	1,365	1,590
SCB47.5	54 (16)	7½	2 <sup>2</sup>	490	520	610	690	760	945	760	945
			3	675	675	895	1,000	990	1,260	990	1,260
MSCB47.5	68 (14)	7½	2 <sup>2</sup>	490	520	780	690	1,055	1,200	1,195	1,475
			3	675	675	1,070	1,000	1,220	1,540	1,365	1,590
SCB49.5	54 (16)	9½	2 <sup>2</sup>	490	520	690	690	760	945	760	945
			3	675	675	895	1,000	990	1,260	990	1,260
SCB411.5	54 (16)	11½	2 <sup>2</sup>	490	520	690	690	990	920	990	920
			3	675	675	860	1,000	990	1,260	990	1,260

For SI: 1 mil = 0.0254 mm, 1 inch = 25.4 mm, 1 lb = 4.45 N.

- Figure 1 of this report shows anchorage options.
- For #12-14 self-drilling screws and welded anchorages: All anchorage options will achieve tabulated allowable loads, except for shaded values, where the allowable load shall be the least of the tabulated value and the allowable load from the selected anchorage in Table 1B.
- When the MSCB/SCB connector is used with two shouldered screws, the screws may be installed in any two slots.

**TABLE 1B – ALLOWABLE LOADS FOR MSCB/SCB SERIES CONNECTOR ANCHORAGE<sup>1</sup>**

Anchorage Type	No. of Anchors	Allowable Loads (lbs.)			
		SCB		MSCB	
		F2	F3	F2	F3
#12-14 Self-Drilling Screws	2	795		795	
	3	1,120		1,365	
	4	No Reduction		No Reduction	
PDPAT <sup>2</sup>	2	440	-	520	-
	3	585	-	780	-
	4	895	-	1,040	-
Welded	N/A	No Reduction		No Reduction	

For SI: 1 mil = 0.0254 mm, 1 inch = 25.4 mm, 1 lb = 4.45 N.

- Tabulated allowable loads are based on anchorage capacity only and do not consider the connector attachment to the supported member. The capacity of the connection system will be the minimum of the tabulated value and the allowable load from Table 1A of this report. [Figure 1](#) of this report shows anchorage options.
- The entire pointed portion of the fastener must penetrate through base steel.
- Allowable loads are based on anchors installed in minimum 3/16" thick structural steel with  $F_y = 36$  ksi.

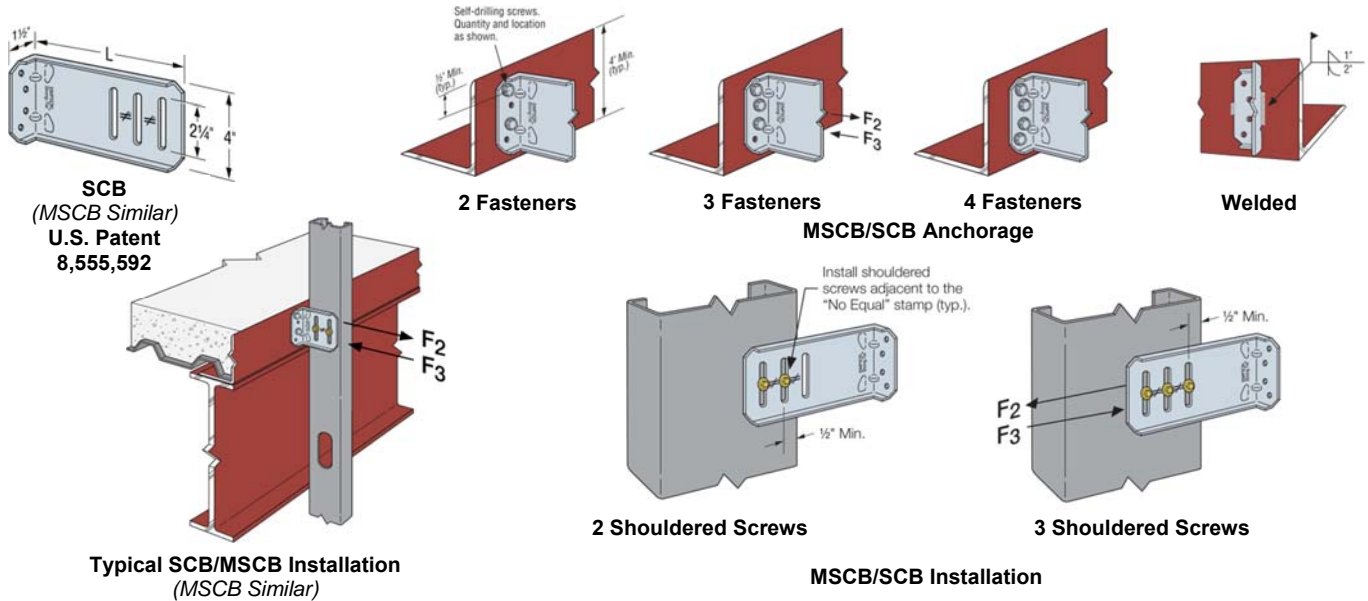

FIGURE 1 – SCB BYPASS SLIDE-CLIP CONNECTORS



TABLE 2 – ALLOWABLE LOADS FOR SSB CONNECTOR<sup>1</sup>

Model No.	Connector Material Thickness mil (ga.)	No. of #14 Shouldered Screws In Slotted Holes	Allowable Load (lbs)					
			Supported Member Thickness					
			33 mil (20 ga.)		43 mil (18 ga.)		54 mil (16 ga.)	
			F2	F3	F2	F3	F2	F3
SSB3.518	54 (16)	2 <sup>2</sup>	520	520	690	690	1,075	960
		3	815	815	1,030	1,080	1,335	1,225

For SI: 1 mil = 0.0254 mm, 1 inch = 25.4 mm, 1 lb = 4.45 N.

- Figure 2 of this report illustrates anchorage options. All anchorage options will achieve tabulated allowable loads, except for shaded values, where the allowable load shall be reduced to 1,250 lbs. for anchorage with 2-#12 screws.
- When the SSB3.518 connector is used with 2 shouldered screws, the screws may be installed in any 2 slots.

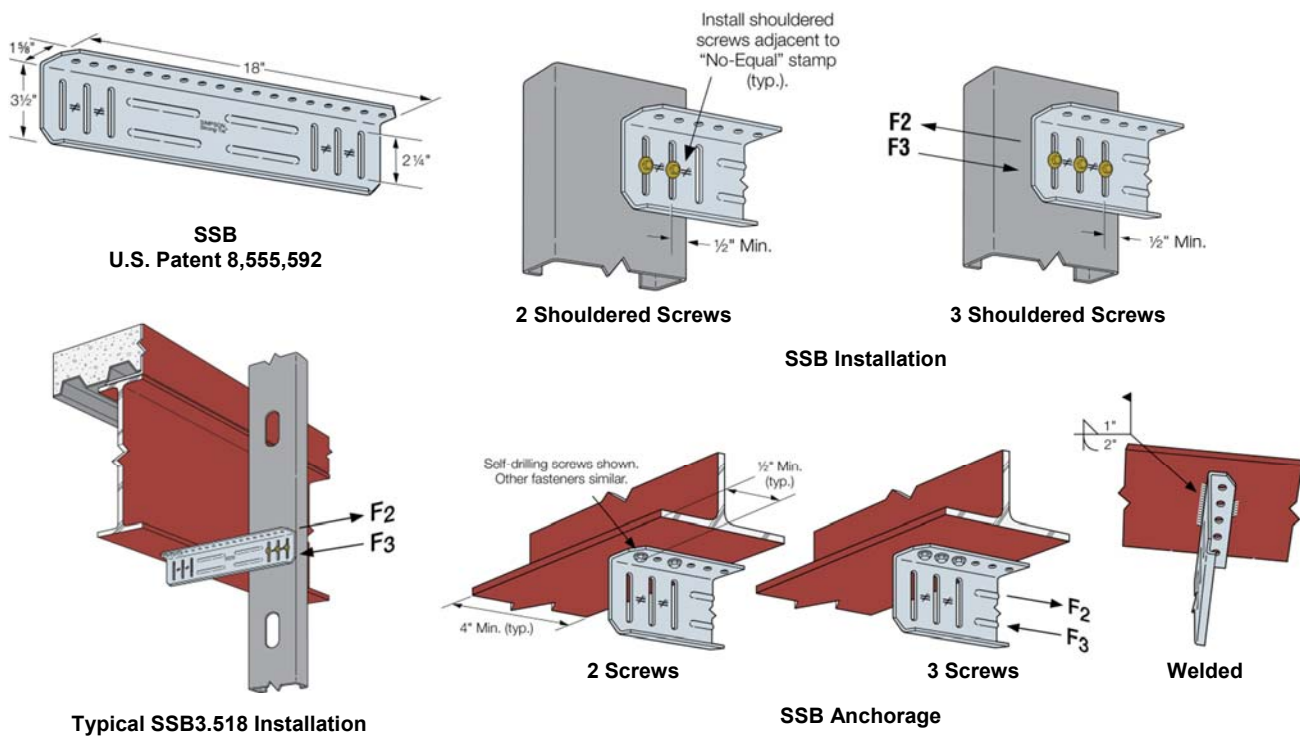

FIGURE 2 – SSB3.518 BYPASS STRUT CONNECTOR

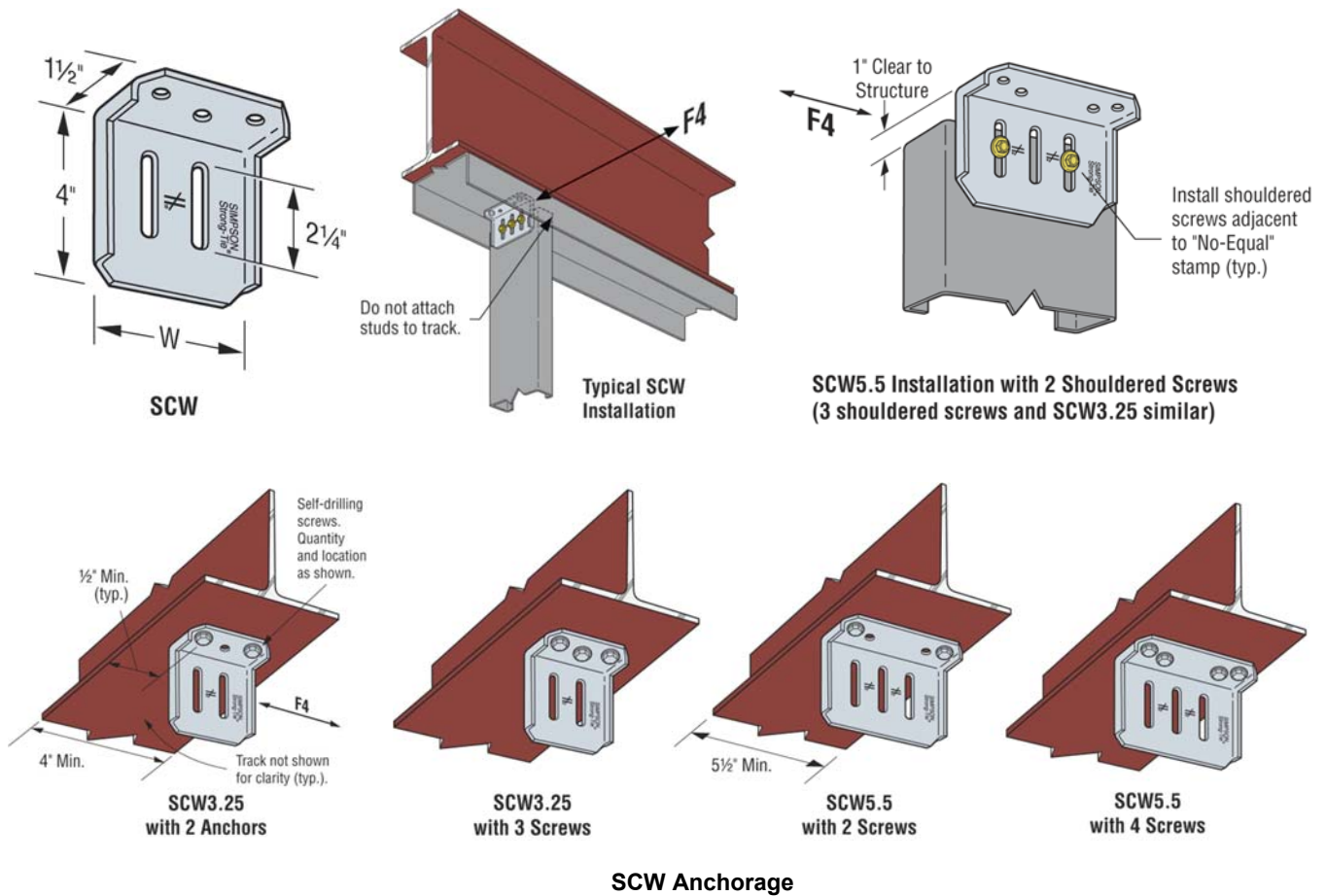

**TABLE 3 – ALLOWABLE LOADS FOR SCW SERIES CONNECTORS<sup>1</sup>**

Model No.	Connector Material Thickness mil (ga.)	W (in.)	No. of #14 Shouldered Screws In Slotted Holes	Allowable Load (lbs)		
				Supported Member Thickness		
				33 mil (20 ga.)	43 mil (18 ga.)	54 mil (16 ga.)
SCW3.25	54 (16)	3¼	2	455	630	755
SCW5.5	54 (16)	5½	2 <sup>2</sup>	455	630	995
			3	455	630	1,220

For SI: 1 mil = 0.0254 mm, 1 inch = 25.4 mm, 1 lb = 4.45 N.

- Figure 3 of this report provides anchorage options. All anchorage options will achieve tabulated allowable loads, except for shaded values, where the allowable load shall be reduced for anchorage with 2-#12 screws to 640 lbs. for the SCW3.25 and 1,200 lbs. for the SCW5.5.
- When the SCW5.5 connector is used with two shouldered screws, install screws in the outermost slots.



**FIGURE 3 – SCW HEAD-OF-WALL CONNECTORS**



**TABLE 4A – ALLOWABLE LOADS FOR FCB SERIES CONNECTORS<sup>2</sup>**

Model No.	Connector Material Thickness mil (ga.)	L (in.)	Min./Max. <sup>1</sup>	No. of #12-14 Self-Drilling Screws	Allowable Load (lbs)								
					Supported Member Thickness								
					33 mil (20 ga.)			43 mil (18 ga.)			54 mil (16 ga.)		
					F2	F3	F4	F2	F3	F4	F2	F3	F4
FCB43.5	54 (16)	3½	Min.	4	755	755	755	1,105	975	1,120	1,250	975	1,490
			Max.	6	1,100	1,130	1,130	1,105	1,260	1,455	1,250	1,735	1,910
FCB45.5	54 (16)	5½	Min.	4	755	755	755	1,105	975	945	1,105	975	1,325
			Max.	9	1,100	1,260	1,180	1,105	1,260	1,485	1,105	1,735	1,925
FCB47.5	54 (16)	7½	Min.	4	755	755	220	1,105	945	330	1,105	945	365
			Max.	12	1,100	1,260	705	1,105	1,260	1,050	1,105	1,735	1,445
FCB49.5	54 (16)	9½	Min.	4	755	755	170	1,105	945	255	1,105	945	365
			Max.	12	1,100	1,260	750	1,105	1,260	1,115	1,105	1,735	1,200
FCB411.5	54 (16)	11½	Min.	4	755	755	140	1,105	920	205	1,105	920	365
			Max.	12	1,100	1,260	795	1,105	1,260	860	1,105	1,735	860

For SI: 1 mil = 0.0254 mm, 1 inch = 25.4 mm, 1 lb = 4.45 N.

- To obtain allowable loads tabulated for Min. fasteners, all round holes shall be filled. For allowable loads tabulated for Max. fasteners, all round and triangle holes shall be filled.
- Tabulated allowable loads are based on connector capacity only and do not consider anchorage. The capacity of the connection system will be the minimum of the tabulated value and the allowable load from Table 4B of this report.

**TABLE 4B – ALLOWABLE LOADS FOR FCB SERIES CONNECTOR ANCHORAGE<sup>1</sup>**

Anchorage Type	No. of Anchors	Allowable Loads (lbs.)								
		F2 and F3	F4							
			FCB43.5	FCB45.5	FCB47.5		FCB49.5		FCB411.5	
			Min./Max.	Min./Max.	Min.	Max.	Min.	Max.	Min.	Max.
#12-14 Self-Drilling Screws	2	795	625	410	255	445	185	265	120	190
	3	1,120	690	450	280	490	200	295	135	210
	4	1,585	1,255	820	365	890	350	535	275	380
PDPAT <sup>4</sup>	2	390 <sup>2</sup>	535 <sup>3</sup>				-			
	3	715 <sup>2</sup>	560 <sup>3</sup>				-			
	4	970 <sup>2</sup>	560 <sup>3</sup>				-			
Welded	Hard side: 2" Free side: 1"	1,735	1,910	1,925	365	1,445	365	1,200	365	860

For SI: 1 inch = 25.4 mm, 1 lb = 4.45 N.

- Tabulated allowable loads are based on anchorage capacity only and do not consider the connector attachment to the supported member. The capacity of the connection system will be the minimum of the tabulated value and the allowable load from Table 4A of this report. [Figure 4](#) of this report shows anchorage options.
- Allowable loads are for F2 direction only.
- Tabulated F4 values with PDPAT are based on testing with FCB47.5.
- The entire pointed portion of the fastener must penetrate through base steel.
- Allowable loads are based on anchors installed in minimum 3/16" thick structural steel with Fy = 36 ksi.

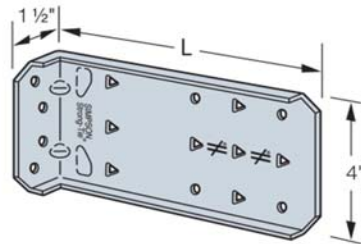

**FCB**  
U.S. Patent  
8,555,592

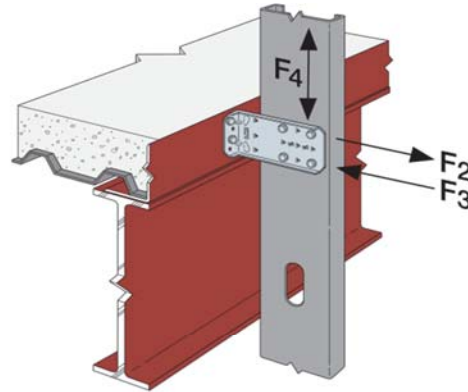

**Typical FCB Installation**

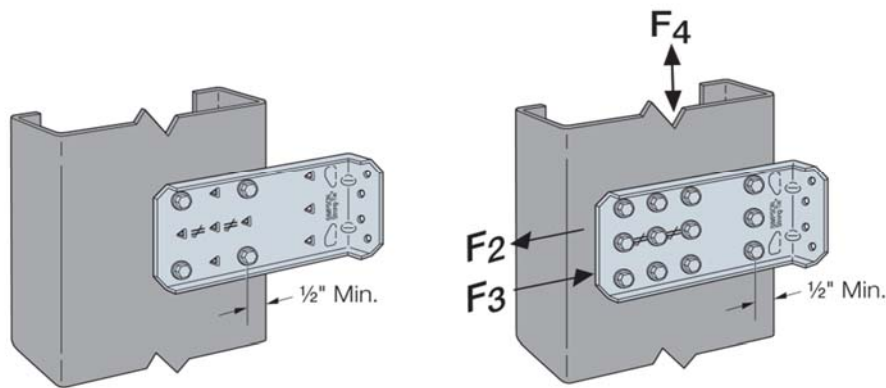

**Min. Fasteners**

**Max Fasteners**

**FCB Installation**

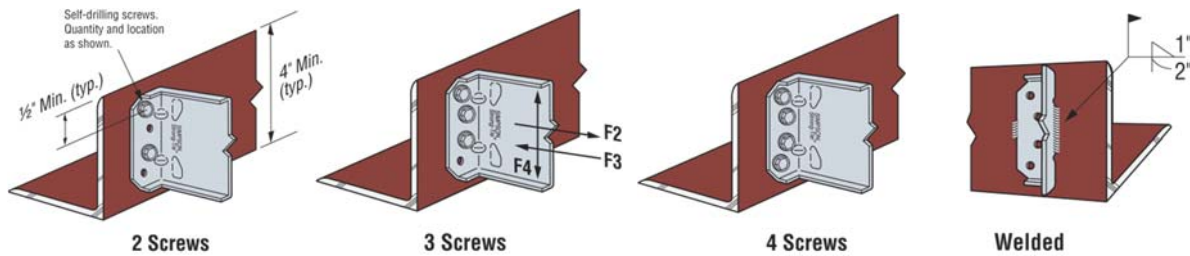

**2 Screws**

**3 Screws**

**4 Screws**

**Welded**

**FCB Anchorage**

**FIGURE 4 – FCB BYPASS FIXED-CLIP CONNECTORS**

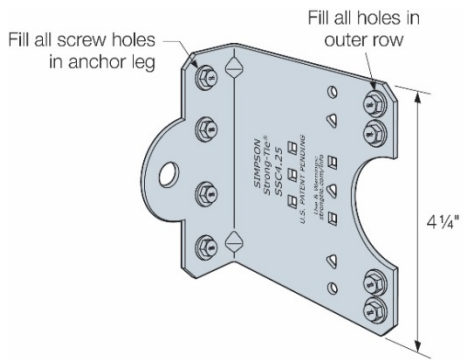
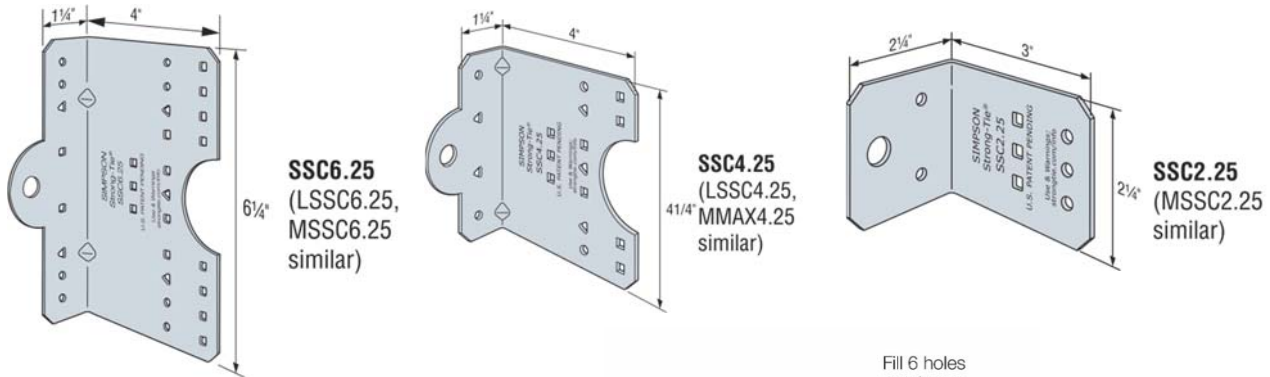

**TABLE 5 – ALLOWABLE LOADS FOR SSC SERIES STEEL STUD CONNECTORS**

Model No.	Connector Material Thickness mil (ga.)	L (in.)	Framing Member Depth (in.)	Fasteners			Allowable F4 Loads (lbs.) <sup>3</sup>			Maximum Connector Load <sup>4</sup>
				Pattern <sup>2</sup>	Carried Member	Carrying Member	Minimum Member Thickness			
							33 mil (20ga.)	43 mil (18ga.)	54 mil (16ga.)	
SSC2.25	68 (14)	2¼	3⅝	Min.	3 - #10	2 - #10	165	225	345	635
MSSC2.25	97 (12)	2¼	3⅝	Min.	3 - #10	2 - #10	165	225	345	635
LSSC4.25	54 (16)	4¼	6	Min.	2 - #10	2 - #10	215	440	675	1490
				Max.	5 - #10	4 - #10	215	440	725	
				Outer	4 - #10	4 - #10	200	310	520	
SSC4.25	68 (14)	4¼	6	Min.	2 - #10	2 - #10	355	525	890	1490
				Max.	5 - #10	4 - #10	365	600	1005	
				Outer	4 - #10	4 - #10	235	330	625	
MSSC4.25	97 (12)	4¼	6	Min.	2 - #10	2 - #10	355	525	890	1490
				Max.	5 - #10	4 - #10	365	600	1005	
				Outer	4 - #10	4 - #10	235	330	625	
LSSC6.25	54 (16)	6¼	8	Min.	4 - #10	4 - #10	265	660	1190	2395
				Max.	7 - #10	6 - #10	265	660	1190	
				Outer	6 - #10	4 - #10	270	375	695	
SSC6.25	68 (14)	6¼	8	Min.	4 - #10	4 - #10	385	720	1190	2395
				Max.	7 - #10	6 - #10	385	720	1190	
				Outer	6 - #10	4 - #10	270	460	725	
MSSC6.25	97 (12)	6¼	8	Min.	4 - #10	4 - #10	385	720	1190	2395
				Max.	7 - #10	6 - #10	385	720	1365	
				Outer	6 - #10	4 - #10	270	460	725	

For SI: 1 mil = 0.0254 mm, 1 inch = 25.4mm, 1lb = 4.45 N.

1. Tabulated allowable loads shall not be increased for wind or seismic load.
2. For Min. fastener quantity and allowable load values - fill all round holes; Max. fastener quantity and allowable load values - fill all round and triangular holes.
3. Allowable loads are based on bracing of the members located within 12" of the connection.
4. Maximum allowable load for connector that may not be exceeded when designing custom installations. Designer is responsible for member and fastener design.



**SSC4.25 – Outer Fastener Pattern**  
(LSSC4.25 and MSSC4.25 Similar)

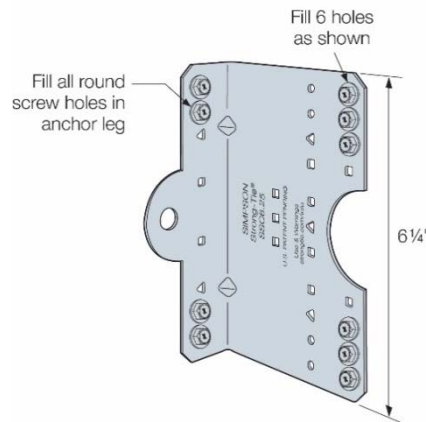

**SSC6.25 – Outer Fastener Pattern**  
(LSSC6.25 and MSSC6.25 Similar)

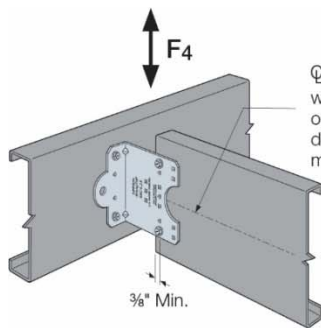

Typical SSC Installation

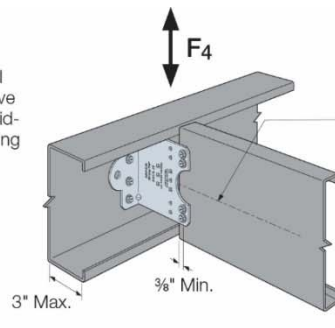

SSC Installation with Carried Member Fasteners in Outer Row

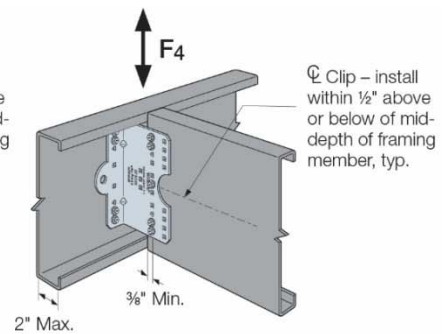

SSC Installation with Carried Member Fasteners in Inner Row

**FIGURE 5 – SSC STEEL STUD CONNECTORS**

**Table 5.1 – ALLOWABLE LOADS FOR SSC CONNECTORS: BYPASS FRAMING**

Model No.	Connector Material Thk mil (ga.)	L (in.)	Fasteners <sup>3</sup>		Allowable Loads (lbs.)											
			Anchorage	Stud	33 mil (20 ga.)				43 mil (18 ga.)				54 mil (16 ga.)			
					F1	F2	F3	F4	F1	F2	F3	F4	F1	F2	F3	F4
SSC4.25	68 (14)	4¼	3 - #12	4 - #10	40	705	705	700	40	870	1050	850	40	935	1210	850
			3 - PDPAT <sup>4</sup>	4 - #10	-	780	-	1,230	-	780	-	1,230	-	780	-	1,230
MSSC4.25	97 (12)	4¼	3 - #12	4 - #10	105	705	705	705	105	780	780	880	105	780	1210	880
			3 - PDPAT <sup>4</sup>	4 - #10	-	780	-	1,230	-	780	-	1,230	-	780	-	1,230

For SI: 1 mil = 0.0254 mm, 1 inch = 25.4mm, 1lb = 4.45 N.

1. Allowable loads are based on anchors installed in minimum 3/16" thick structural steel with  $F_y = 36$  ksi.
2. See Figure 5.1 for fastener placement.
3. Allowable loads based on in-plane loads applied at the centroid of the fasteners to the stud, with no rotational restraint of stud.
4. The entire pointed portion of the fastener must penetrate through base steel.

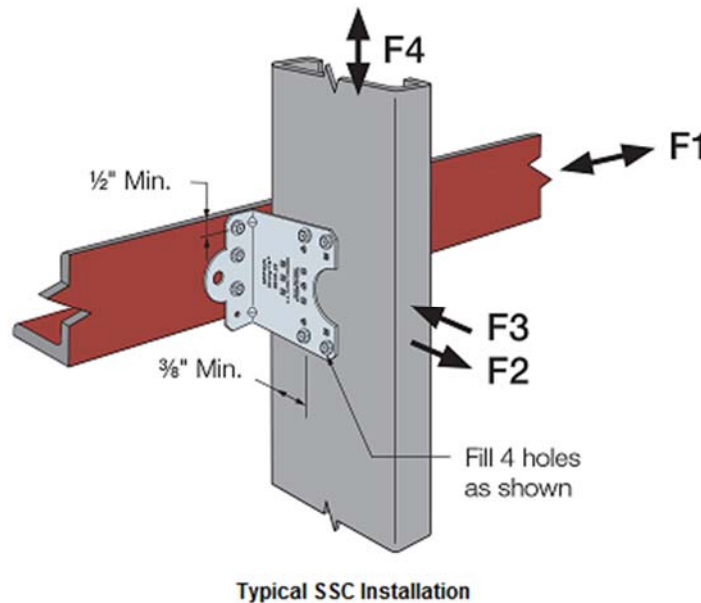

**FIGURE 5.1 – SSC CONNECTORS: BYPASS FRAMING**

**TABLE 5.2 – ALLOWABLE LOADS FOR SSC CONNECTORS: HEADERS**

Model No.	Connector Material Thickness mil (ga.)	L (in.)	Jamb Stud Depth (in.)	Fasteners			Jamb & Header Thickness mil (ga.)	Allowable F3 Loads (lbs.)		Allowable F4 Loads (lbs.)
				Pattern <sup>2</sup>	Jamb	Header		Nested Stud & Track Header	Back to Back Header <sup>3</sup>	
LSSC4.25	54 (16)	4¼	6	Max.	5 - #10	4 - #10	33 (20)	140	455	215
							43 (18)	220	660	440
SSC4.25	68 (14)	4¼	6	Max.	5 - #10	4 - #10	54 (16)	375	1055	1005
							68 (14)	570	1055	1005
LSSC6.25	54 (16)	6¼	8	Max.	7 - #10	6 - #10	33 (20)	160	455	265
							43 (18)	250	730	660
SSC6.25	68 (14)	6¼	8	Max.	7 - #10	6 - #10	54 (16)	410	1110	1190
							68 (14)	640	1110	1190

For SI: 1 mil = 0.0254 mm, 1 inch = 25.4 mm, 1 lb = 4.45 N.

1. For Max. fastener quantity and allowable load values – fill all round and triangular holes.
2. Designer is responsible for checking web crippling of the header and reducing allowable loads accordingly.
3. Tabulated values apply to Box Header per illustration below.

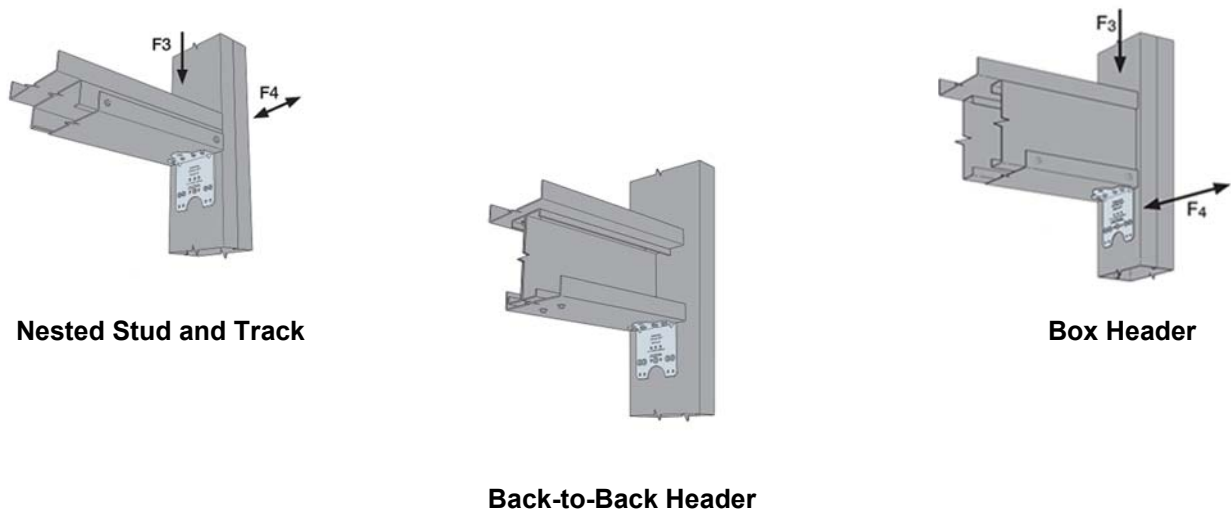

**FIGURE 5.2 – SSC CONNECTORS: HEADERS**

**TABLE 5.3 – ALLOWABLE LOADS FOR SSC CONNECTORS: BASE OF JAMB**

Model No.	Connector Material Thickness mil (ga.)	L (in.)	Stud Member Depth (in.)	Fasteners		Stud Thickness mil (ga.)	Allowable F4 Load (lbs.)
				Anchor Dia.	Stud Fasteners <sup>4</sup>		
SSC2.25	68 (14)	2¼	3⅝	⅜	3-#10	33 (20)	390
						43 (18)	605
						54 (16)	940
SSC4.25	68 (14)	4¼	6	⅜	5-#10	33 (20)	420
						43 (18)	685
						54 (16)	975
SSC6.25	68 (14)	6¼	8	⅜	7-#10	33 (20)	470
						43 (18)	715
						54 (16)	1020

For SI: 1 mil = 0.0254 mm, 1 inch = 25.4mm, 1 lb = 4.45 N

1. Allowable loads are based on minimum 33 mil (20 ga.) track for 33 mil (20 ga.) and 43 mil (18 ga.) studs, and minimum 43 mil (18 ga.) track for 16 ga. studs, with one #10 screw into each stud flange.
2. Allowable loads assume adequate torsional bracing is provided. Bracing design is the responsibility of the designer.
3. Designer is responsible for anchorage design.
4. See Figure 5.3 for fastener placement.

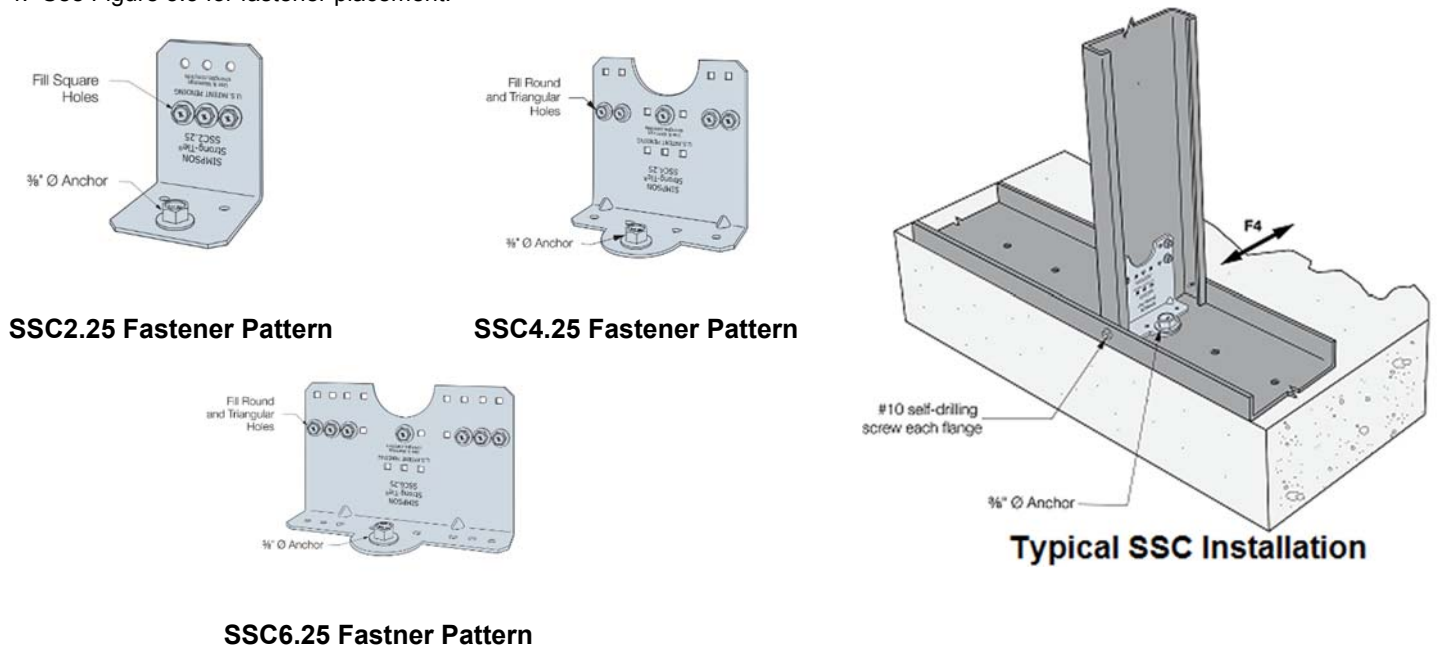

**FIGURE 5.3 – SSC CONNECTORS: BASE OF JAMB**

**TABLE 5.4 – ALLOWABLE LOADS FOR SSC CONNECTORS: RAFTERS**

Model No.	Connector Material Thickness mil (ga.)	L (in.)	Fasteners <sup>2</sup>		Allowable Loads (lbs.)		
			Anchorage to Steel <sup>3</sup>	Supported Member	43 mil (18 ga.)		
					F2	F3	F4
SSC4.25	68 (14)	4¼	2 - #12	5 - #10	710	1075	595
MSSC4.25	97 (12)	4¼	2 - #12	5 - #10	710	1335	595

For SI: 1 mil = 0.0254 mm, 1 inch = 25.4mm, 1lb = 4.45 N.

1. See Figure 5.4 for fastener placement.
2. Allowable loads are based on anchors installed in minimum 3/16" thick structural steel with  $F_y = 36$  ksi.
3. Allowable loads are based on a 6" deep member. For deeper members, designer must consider web crippling of the member and reduce loads accordingly.

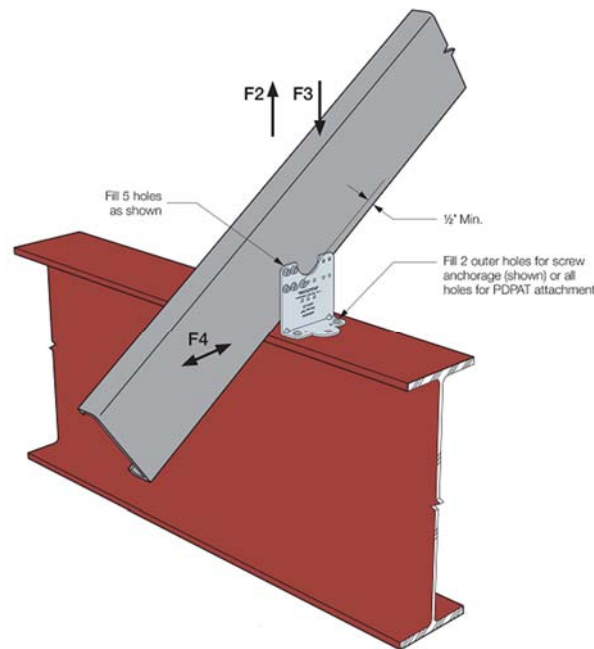

**Typical Installation**

**FIGURE 5.4 – SSC CONNECTORS: RAFTER**

**TABLE 5.5 – ALLOWABLE LOADS FOR SSC CONNECTORS: U-CANNEL BRIDGING**

Model No.	Connector Material Thk. mil (ga.)	L (in.)	Stud Depth (in.)	Stud Thk. mil (ga.)	Fasteners <sup>2</sup>		Laterally Loaded C-Stud	Axially Loaded C-Stud	
					Stud	Bridging	Allowable Torsional Moment <sup>3</sup> (in.-lbs.)	Allowable Brace Strength <sup>3</sup> (lbs.)	Brace Stiffness (lbs. / in.)
SSC4.25	68 (14)	4¼	6	54 (16)	2 - #10	2 - #10	655	280	2045
				68 (14)	2 - #10	2 - #10	805	335	2305
				97 (12)	2 - #10	2 - #10	920	660	4230

For SI: 1 mil = 0.0254 mm, 1 inch = 25.4mm, 1lb = 4.45 N

1. See Figure 5.5 for fastener placement.
2. Allowable loads are for use when utilizing Allowable Stress Design methodology. For LRFD loads, multiply the tabulated ASD values by 1.6.
3. Tabulated stiffness values apply to both ASD and LRFD designs.

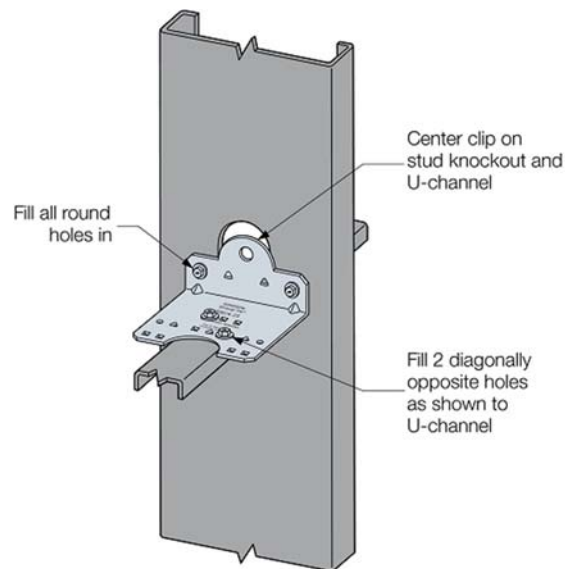

**Typical SSC4.25 Installation**

**FIGURE 5.5 – SSC CONNECTORS: U-CANNEL BRIDGING**

**TABLE 5.6 - ALLOWABLE LOADS FOR MSSC CONNECTORS: KNEEWALL**

Model No.	Conn. Material Thk. mil (ga.)	L (in.)	Framing Member Depth (in.)	Fasteners		Stud Thk. mil (ga.)	Allowable Moment, M (in.-lbs.) <sup>2</sup>	Anchor Tension at Allowable Moment (lbs.) <sup>3</sup>	Rotational Stiffness for Wind Defl. (in.-lbs./rad.) <sup>4</sup>
				Anchor Dia. (in.)	Stud				
MSSC4.25KW	97 (12)	4¼	6	¾	8 - #10	33 (20)	3135	1610	64,800
						43 (18)	4320	2305	
						54 (16)	5830	3300	
MSSC6.25KW	97 (12)	6¼	8	¾	12 - #10	33 (20)	3845	1290	110,350
						43 (18)	3845	1290	
						54 (16)	8350	2980	

For SI: 1 mil = 0.0254 mm, 1 inch = 25.4mm, 1 lb = 4.45 N

1. Tabulated values correspond to maximum connector strength without consideration of serviceability. Designer must check out-of-plane deflections using tabulated rotational stiffness.
2. Uplift may be linearly interpolated for design moment less than allowable.
3. Tabulated stiffness is applicable for walls up to 38" tall. For taller walls, the designer must consider additional deflection due to bending in the studs.
4. Tabulated stiffness has been increased for deflection checks using component and cladding wind loads in lieu of reducing loads in accordance with IBC table 1604.3, footnote f. Multiply rotational stiffness by 0.7 for other loading conditions.

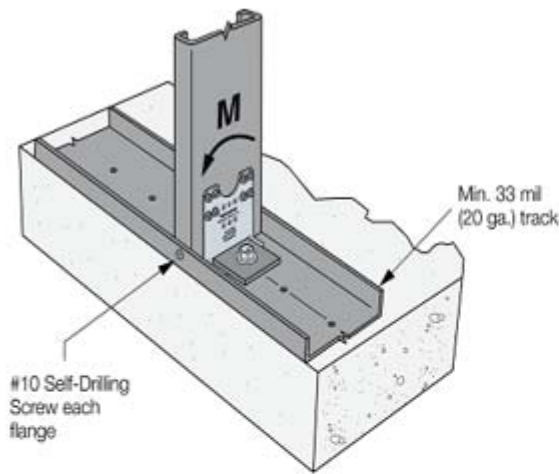

**Typical MSSCKW Installation**



**MSSC4.25KW Fastener Pattern**



**MSSC6.25KW Fastener Pattern**

**FIGURE 5.6 – SSC CONNECTORS: KNEEWALL**

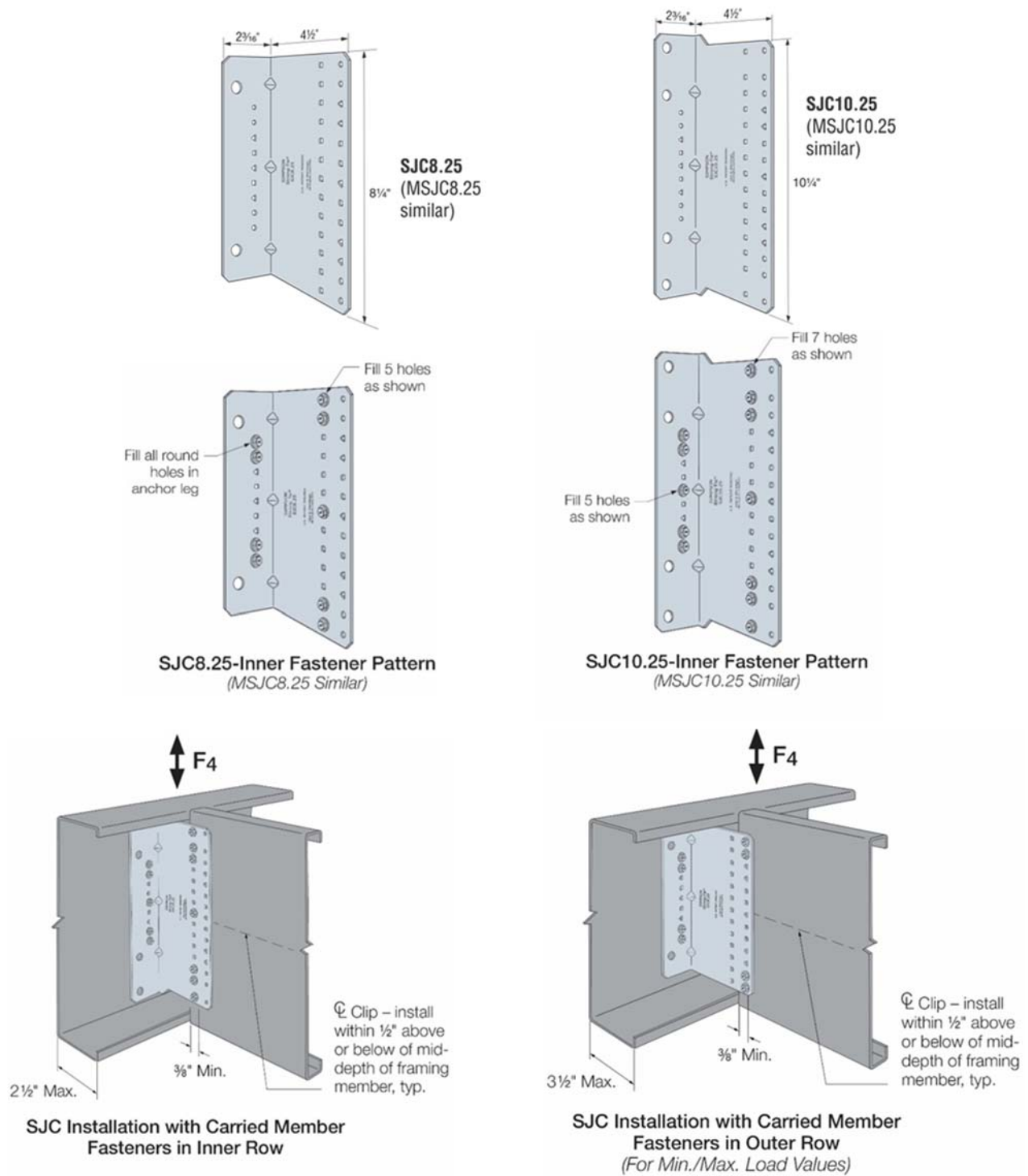

**TABLE 6 – ALLOWABLE LOADS FOR SJC SERIES STEEL JOIST CONNECTORS**

Model No.	Connector Material Thickness mil (ga.)	L (in.)	Framing Member Depth (in.)	Fasteners		Allowable F4 Loads (lbs.) <sup>3</sup>			
				Pattern <sup>2</sup>	Carried Member	Carrying Member	Minimum Member Thickness		Maximum Connector Load <sup>4</sup>
							54 mil (16 ga.)	68 mil (14 ga.)	
SJC8.25	68 (14)	8¼	10	Min.	4 - #10	4 - #10	980	980	2715
				Max.	9 - #10	7 - #10	1005	1490	
				Inner	5 - #10	4 - #10	1345	2005	
MSJC8.25	97 (12)	8¼	10	Min.	4 - #10	4 - #10	1005	1710	2715
				Max.	9 - #10	7 - #10	1135	1765	
				Inner	5 - #10	4 - #10	1535	2220	
SJC10.25	68 (14)	10¼	12	Min.	6 - #10	4 - #10	1170	1625	3640
				Max.	11 - #10	7 - #10	1265	1625	
				Inner	7 - #10	5 - #10	1620	2170	
MSJC10.25	97 (12)	10¼	12	Min.	6 - #10	4 - #10	1200	2045	3640
				Max.	11 - #10	7 - #10	1265	2045	
				Inner	7 - #10	5 - #10	1730	2635	

For SI: 1 mil = 0.0254 mm, 1 inch = 25.4mm, 1lb = 4.45 N.

1. Tabulated allowable loads shall not be increased for wind or seismic load.
2. For Min. fastener quantity and allowable load values - fill all round holes; Max fastener quantity and allowable load values fill all round and triangular holes.
3. Allowable loads are based on bracing of the members located within 12" of the connection.
4. Maximum allowable load for connector that may not be exceeded when designing custom installation. Designer is responsible for member and fastener.



**FIGURE 6 – SJC STEEL STUD CONNECTORS**

**TABLE 6.1 – ALLOWABLE LOADS FOR SJC CONNECTORS: KICKER**

Model No.	Connector Material Thickness mil (ga.)	L (in.)	Fasteners		Kicker Angle	Maximum Load (lbs.)
			Anchor Dia. (in.)	Screws to Kicker		
SJC8.25	68 (14)	8¼	¾	6 - #10	30°	490
					45°	535
SJC10.25	68 (14)	10¼	¾	6 - #10	30°	625
					45°	530
MSJC10.25	97 (12)	10¼	¾	6 - #10	30°	950
					45°	780

For SI: 1 mil = 0.0254 mm, 1 inch = 25.4mm, 1lb = 4.45 N.

1. Loads apply to connectors installed perpendicular or parallel to deck flutes, with minimum 33 mil (20 ga.) kicker.
2. Kicker angle is the acute angle measured relative to the horizontal plane of the metal deck.

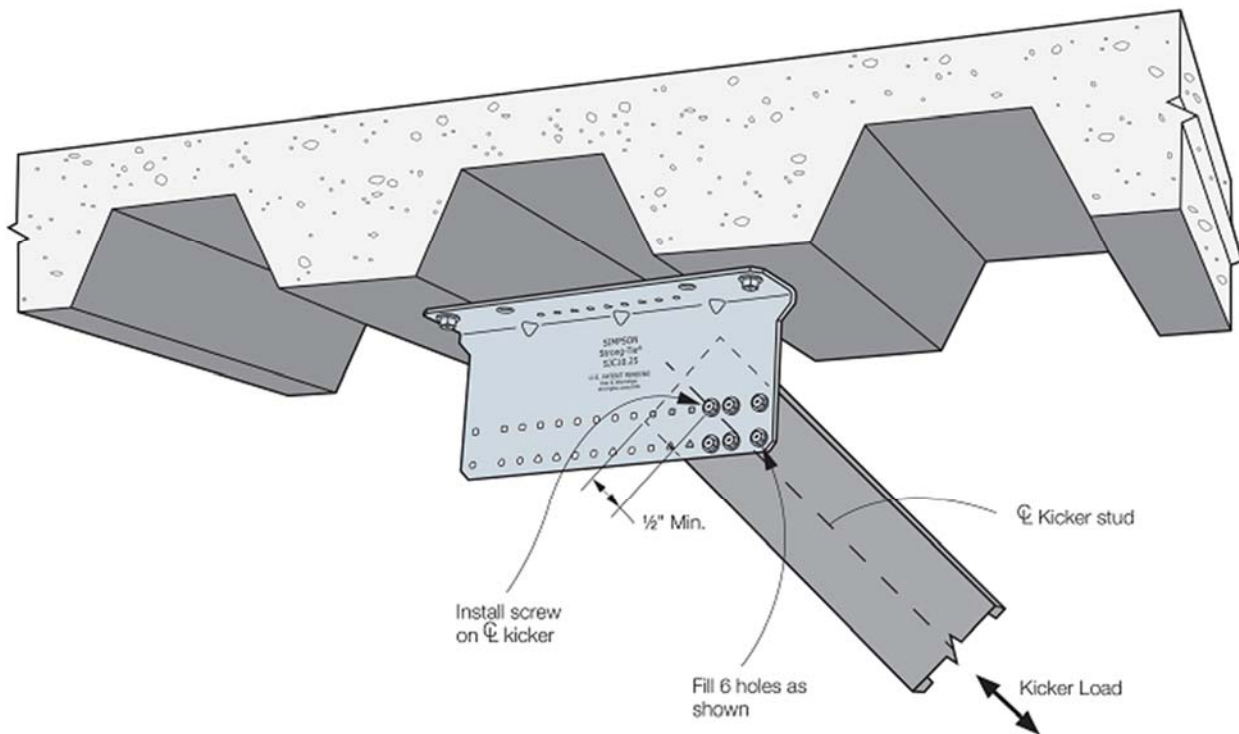

**Typical SJC Installation (MSJC Similar)**

**FIGURE 6.1 – SJC CONNECTORS: KICKER**

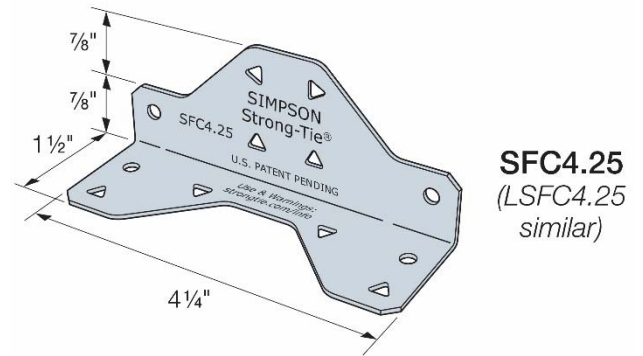
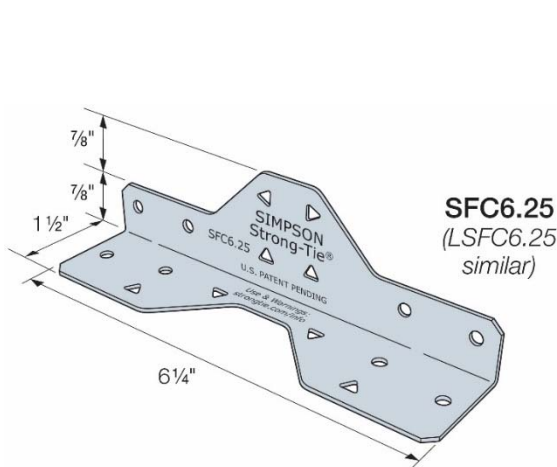

**TABLE 7 – ALLOWABLE LOADS FOR SFC SERIES STEEL FRAMING CONNECTORS**

Model No.	Connector Material Thickness mil (ga.)	L (in.)	Framing Member Depth (in.)	Fasteners			Allowable F4 Loads (lbs.) <sup>3</sup>			
				Pattern <sup>2</sup>	Carried Member	Carrying Member	Minimum Member Thickness			Maximum Connector Load <sup>4</sup>
							33 mil	43 mil	54 mil	
							(20 ga.)	(18 ga.)	(16 ga.)	
LSFC2.25	43 (18)	2¼	3⅝	Min.	2 - #10	2 - #10	295	310	475	585
SFC2.25	54 (16)	2¼	3⅝	Min.	2 - #10	2 - #10	295	355	630	585
LSFC4.25	43 (18)	4¼	6	Min.	2 - #10	2 - #10	355	525	525	1615
				Max.	6 - #10	6 - #10	440	865	1320	
SFC4.25	54 (16)	4¼	6	Min.	2 - #10	2 - #10	355	525	745	1615
				Max.	6 - #10	6 - #10	575	750	1615	
LSFC6.25	43 (18)	6¼	8	Min.	4 - #10	4 - #10	490	920	1050	2440
				Max.	8 - #10	8 - #10	510	980	1495	
SFC6.25	54 (16)	6¼	8	Min.	4 - #10	4 - #10	590	1035	1840	2440
				Max.	8 - #10	8 - #10	590	1055	1880	

For SI: 1 mil = 0.0254 mm, 1 inch = 25.4mm, 1lb = 4.45 N.

1. Tabulated allowable loads shall not be increased for wind or seismic load.
2. For Min. fastener quantity and allowable load values - fill all round holes; Max. fastener quantity and allowable load values - fill all round and triangular holes.
3. Allowable loads are based on bracing of the members located within 12" of the connection.
4. Maximum allowable load for connector that may not be exceeded when designing custom installations. Designer is responsible for member and fastener design.



**SFC**  
U.S. Patent  
9,016,024

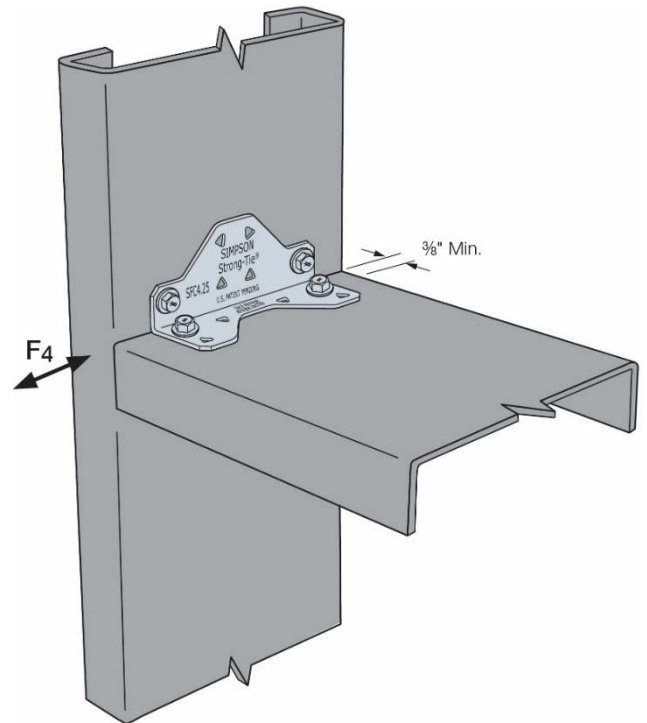
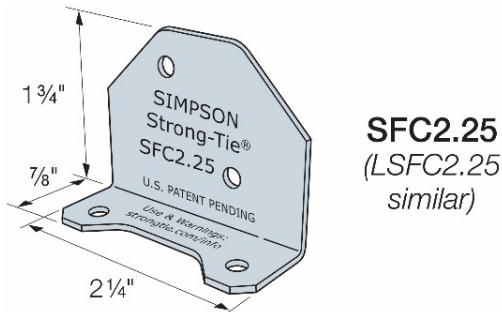

**FIGURE 7 – SFC STEEL FRAMING CONNECTORS**

**TABLE 7.1 – ALLOWABLE LOADS FOR SFC CONNECTORS: U-CHANNEL BRIDGING**

Model No.	Connector Material Thickness mil (ga.)	L (in.)	Stud Depth (in.)	Stud Thickness mil (ga.)	Fasteners <sup>2</sup>		Laterally Loaded C-Stud	Axially Loaded C-Stud	
					Stud	Bridging	Allowable Torsional Moment <sup>3</sup> (in.-lbs.)	Allowable Brace Strength <sup>3</sup> (lbs.)	Brace Stiffness (lbs. / in.)
SFC4.25	54 (16)	4 1/4	6	33 (20)	2 - #10	2 - #10	275	125	860
				43 (18)	2 - #10	2 - #10	510	190	1220
				54 (16)	2 - #10	2 - #10	645	280	2045

For SI: 1 mil = 0.0254 mm, 1 inch = 25.4mm, 1lb = 4.45 N.

1. See Figure 7.1 for fastener placement.
2. Allowable loads are for use when utilizing Allowable Stress Design methodology. For LRFD loads, multiply the tabulated ASD values by 1.6.
3. Tabulated stiffness values apply to both ASD and LRFD designs.

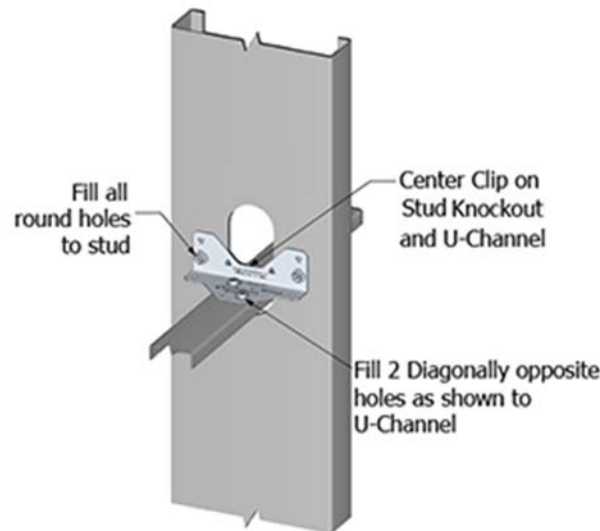

**FIGURE 7.1 – SFC CONNECTORS: U-CHANNEL BRIDGING**

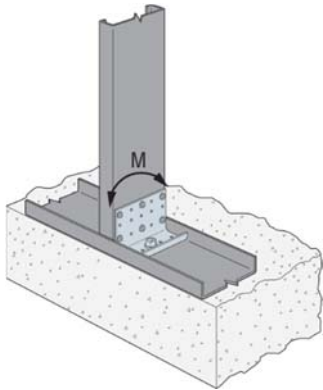

**TABLE 8 – ALLOWABLE LOADS FOR RCKW KNEEWALL CONNECTORS**

Model No.	Fastener Pattern No.	Anchor Dia. <sup>2</sup> (in.)	Fasteners to Stud <sup>3</sup>	Framing Members Thk <sup>4</sup> mil (ga.)	Allowable Moment <sup>4,5</sup> M (in.-lb.)	Assembly Rotational Stiffness <sup>6,8</sup> $\beta$ (in.-lb. / rad.)	Connector Rotational Stiffness <sup>7,8</sup> $\beta_c$ (in.-lb. / rad.)	Anchor Tension, T at Allowable Moment (lb.)	
								f <sub>c</sub> = 3000 psi	f <sub>c</sub> = 4000 psi
RCKW3	1	½	4 - #12	33 (20)	2,425	87,000	92,900	1,870	1,790
				43 (18)	3,080	112,800	115,000	2,510	2,355
				54 (16)	4,330	127,900	136,600	4,120	3,585
RCKW3 & RCKW3S (Stiffener)	2	½	9 - #12	43 (18)	4,215	162,200	179,100	3,935	3,465
				54 (16)	5,160	139,600	149,800	6,700	4,585
				68 (14)	5,160	130,900	136,600	6,700	4,585
RCKW5.5	3	½	6 - #12	33 (20)	4,670	303,900	328,200	1,830	1,795
				43 (18)	6,245	333,100	355,300	2,525	2,450
				54 (16)	8,225	306,000	320,500	3,470	3,320
RCKW5.5 & RCKW5.5S (Stiffener)	4	½	10 - #12	43 (18)	8,445	449,800	489,600	3,580	3,420
				54 (16)	11,575	467,000	502,300	5,340	4,935
				68 (14)	13,935	432,300	456,300	7,020	6,215
RCKW7.5	5	½	6 - #12	33 (20)	6,445	388,500	402,000	1,815	1,790
				43 (18)	8,200	510,400	535,800	2,345	2,305
				54 (16)	11,400	553,900	571,200	3,370	3,275
RCKW7.5 & RCKW5.5S (Stiffener)	6	½	10 - #12	43 (18)	10,915	590,800	623,400	3,210	3,125
				54 (16)	14,045	762,600	808,400	4,275	4,115
				68 (14)	16,670	615,800	631,300	5,245	4,985

For SI: 1 mil = 0.0254 mm, 1 inch = 25.4mm, 1 lb = 4.45 N

- See Figure 9 for screw pattern.
- Designer is responsible for anchorage design.
- Screw length shall be selected based on the total thickness of materials to be joined such that the screws extend through the steel connection a minimum of 3 exposed threads.
- Tabulated values are based on framing members with track and stud of the same thicknesses and #10 screws into each stud flange.
- Tabulated moment values correspond to maximum connector strength without consideration of serviceability. Designer must check out-of-plane deflections using tabulated Assembly Rotational Stiffness.
- Tabulated Assembly Rotational Stiffness is applicable for walls at 38" tall with correspond framing member depth and thickness.
- Tabulated Connector Rotational Stiffness may be use for wall height other than 38" tall; the designer must consider member deflection due to bending in the stud member.
- Tabulated rotational stiffness may be increased for deflection checks using component and cladding wind loads in lieu of reducing loads in accordance with IBC Section 1604.
- Anchor Tension, T, is the force in the anchor at maximum allowable moment, M.



**RCKW5.5 Installation on Concrete**  
*(RCKW 3 and RCKW7.5 similar)*

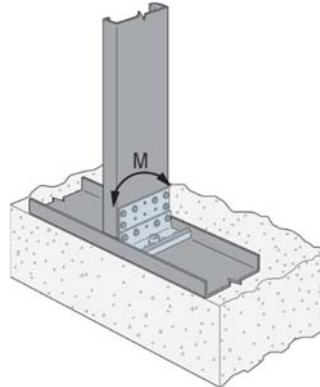

**RCKW5.5 with RCKW5.5S Installation on Concrete**  
*(RCKW3 with RCKW3S and RCKW7.5 with RCKW5.5S similar)*

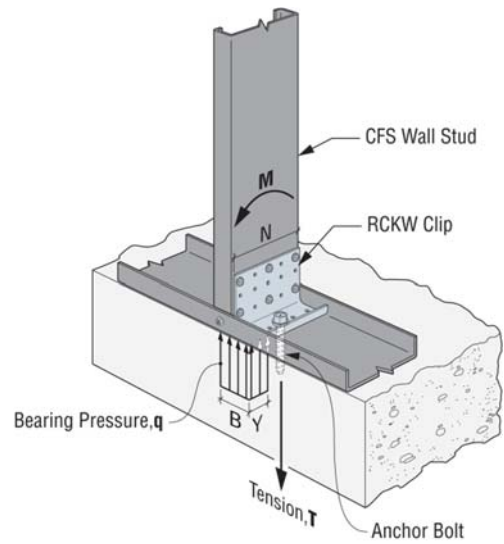

**Anchor Bolt Design**

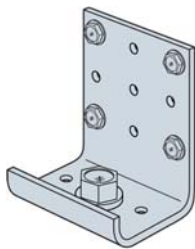

**RCKW3**  
Screw Pattern 1

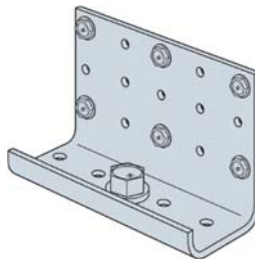

**RCKW5.5**  
Screw Pattern 3

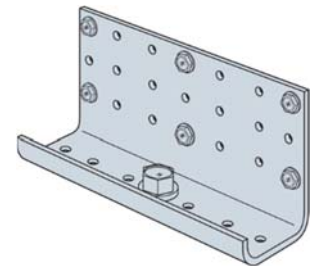

**RCKW7.5**  
Screw Pattern 5

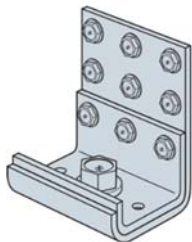

**RCKW3 with RCKW3S**  
Screw Pattern 2

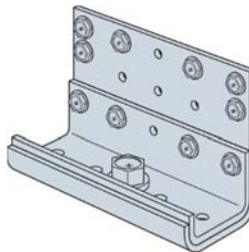

**RCKW5.5 with RCKW5.5S**  
Screw Pattern 4

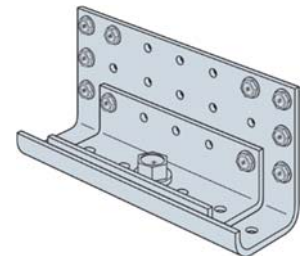

**RCKW7.5 with RCKW5.5S**  
Screw Pattern 6

**FIGURE 8 – RCKW KNEEWALL CONNECTORS**