

# ICC-ES Evaluation Report

**ESR-1118**

Reissued January 2019

This report is subject to renewal January 2021.

[www.icc-es.org](http://www.icc-es.org) | (800) 423-6587 | (562) 699-0543

A Subsidiary of the International Code Council®

**DIVISION: 06 00 00—WOOD, PLASTICS AND COMPOSITES**  
**Section: 06 17 53—Shop-Fabricated Wood Trusses**

**REPORT HOLDER:**

ITW BUILDING COMPONENTS GROUP INC.

**EVALUATION SUBJECT:**

**ALPINE TRUSS PLATES (METAL CONNECTOR PLATES): WAVE, H AND SS, TRULOX AND HINGE PLATES**

**1.0 EVALUATION SCOPE**

**Compliance with the following codes:**

- 2018, 2015 and 2012 *International Building Code*® (IBC)
- 2018, 2015 and 2012 *International Residential Code*® (IRC)

**Property evaluated:**

Structural

**2.0 USES**

Plate Connectors described in this evaluation report are used as joint connector components of light wood frame trusses.

**3.0 DESCRIPTION**

**3.1 Wave Plate™ Truss Plate Connector:**

The Wave Plate™ metal truss connector plates are manufactured from No. 20 gage [minimum 0.0356 inch (0.904 mm) total thickness] steel complying with ASTM A653 SS Grade 40, with a G60 galvanization coating [0.0005-inch (0.013 mm) thickness on each side], and a minimum base-metal thickness of 0.0346 inch (0.879 mm). The Wave Plate is also available with G90 [0.0008-inch (0.019 mm) thickness on each side] and G185 [0.0016-inch (0.040 mm) thickness on each side] galvanizing levels applied to the same minimum base-metal thickness steel as specified for the G60 galvanized Wave Plate. Pairs of teeth are punched forming slots which are 0.12 inch (3.0 mm) wide and 0.50 inch (12.7 mm) long, are aligned parallel to the plate length, and are spaced 0.25 inch (6.35 mm) on center across the width of the plate and 1.0 inch (25.4 mm) on center along the length of the plate. Adjacent teeth are staggered along the length of the plate 0.06 inch (1.52 mm) from each other in a double alternating pattern, resulting in three slot positions: centered in the row; +0.06 inch (1.52 mm) from the center of the row; and -0.06 inch (1.52 mm) from the center of the

row, resulting in an undulating or “wave” pattern within each row of slots. The Wave Plate™ is available in 1-inch (25.4 mm) increments of both width and length. See Figure 1 for details.

**3.2 H and SS Connector Plates:**

H and SS connector plates are manufactured in two forms known as H (High Strength, also referred to as HS) and SS (Super High Strength) from No. 20 gage [minimum 0.0356-inch (0.904 mm) total thickness] and No. 18 gage [minimum 0.0466-inch (1.18 mm) total thickness], respectively, steel complying with ASTM A653 HSLAS Grade 60, with a G90 galvanization coating [0.00075-inch (0.019 mm) thickness on each side], and minimum base-metal thicknesses of 0.0341 inch (0.866 mm) and 0.0451 inch (1.146 mm), respectively. The H and SS plates are also available with G60 [0.0005-inch (0.013 mm) thickness on each side] galvanizing level applied to the same minimum base-metal thickness steel as specified for the G90 galvanized H and S plates. Pairs of 0.115-by-0.327-inch (2.92 by 8.31 mm) teeth are punched perpendicular to the plane of the plate, each pair leaving a 0.115-by-0.49-inch (2.92 by 12.45 mm) slot in the plate. The slots are spaced 0.875 inch (22.23 mm) apart on center lengthwise. Slots are grouped in sets of four, with each set consisting of four slots spaced 0.3125 inch (7.94 mm) apart on center widthwise. Adjacent slots across the width are staggered 0.4375 inch (11.11 mm) lengthwise. Sets of slots are spaced 1.3125 inches (33.34 mm) apart on center widthwise. There are 6.97 teeth per square inch (1.08 teeth/cm<sup>2</sup>) of plate. Teeth are pointed on the end and V-shaped in cross section. See Figure 2 for details.

**3.3 Trulox Connector Plate:**

Trulox nail plates are made from No. 20 gage [minimum 0.0356-inch (0.904mm) total thickness] steel complying with ASTM A653 SS Grade 40, with a G60 galvanization coating [0.0005-inch (0.013 mm) thickness on each side], and a minimum base-metal thickness of 0.0346 inch (0.879 mm). The Trulox Connector Plate is a flat nailing plate without integral teeth, with 0.131-inch-diameter (3.33 mm) nailing holes spaced 1 inch (25.4 mm) on center lengthwise and 0.667 inch (16.94 mm) on center widthwise. Adjacent holes along the length are staggered 0.333 inch (8.38 mm) widthwise. There are 1.5 holes per square inch (645.16 mm<sup>2</sup>) of plate. Plates are connected to wood with separately applied nails, such as 1.375-inch-long (34.93 mm), No. 11 gage diameter [0.1205 inch (3.06 mm)], spiral shank truss nails, or similar. The Trulox nail plate is identified by its hole pattern and the lack of any integral teeth. See Figure 3 for details.

### 3.4 Hinge Plate:

2-by-8 Hinge Plates are made of No. 18 gage [minimum 0.0466-inch (1.18 mm) total thickness] steel complying with ASTM A653 SS Grade 37, with a G60 galvanization coating [0.0005 inch (0.013 mm) thickness on each side], and a minimum base-metal thickness of 0.0456 inch (1.16 mm). The Hinge Plate connector consists of two 2-by-4.5-inch (51 by 114 mm) metal plates, overlapped by 1 inch (25.4 mm) and grommetted together with a brass grommet through a punched hole in each plate. For each side of the hinge plate, three rows of eight pairs of teeth per row are punched perpendicular to the plane of the plate, each pair leaving a 0.12 by 0.50-inch (3.0 by 12.7 mm) slot in the plate. The slots are spaced 1 inch (25 mm) apart on center lengthwise and 0.25 inch (4.2 mm) apart on center widthwise, leaving 48 teeth on each side of the hinge, i.e., a total of 96 teeth per plate. Each slot is offset along its length 0.06 inch (1.52 mm) from the adjacent slots. Teeth are pointed on the end and V-shaped in cross section. See Figure 4 for details.

## 4.0 INSTALLATION

### 4.1 General:

Wave, H, S and Hinge Truss Plates are pressed into the wood for the full depth of their teeth by hydraulic presses, pneumatic presses, or roller presses, or by passing the unit through a stationary roller press.

Design values shown for hydraulic-platen embedment are valid for hydraulic, pneumatic presses, multiple roller presses that use partial embedment followed by full-embedment rollers, or combinations of partial embedment roller presses and hydraulic-platen presses that feed trusses into a stationary finish roller press. Design values shown for single pass roller presses are valid for rollers 18 inches (457.2 mm) or larger in diameter. Trusses must be assembled within the tolerances provided by TPI's Quality Criteria for Metal Plate Connected Wood Trusses, as shown in Section 3 of ANSI/TPI 1, National Design Standard for Metal Plate Connected Wood Truss Construction.

### 4.2 Allowable Design Values:

**4.2.1 Wave, H and SS Truss Plates:** Allowable design values for Wave, H and SS, Truss Plate Connectors used in the design of metal plate connected wood roof and floor trusses are shown in Tables 1 and 2. Allowable design values are applicable when the connection is made with identical plates on opposite sides of the joint. The design, manufacture, and installation of trusses employing the truss plates must comply with IBC Section 2303.4 or IRC Sections R502.11 and R802.10, as applicable.

**4.2.2 Trulox Truss Plate Connector:** This connector is a nail plate using separately applied nails. Effective steel tension strength ratios must be determined based on accepted design principles for steel. Allowable steel shear design values are shown in Table 2. Lateral resistance values must be determined in accordance with the design values for nails in the AF&PA National Design Specification for Wood Construction. Allowable design values are applicable when the connection is made with identical plates and nailing patterns on opposite sides of the joint.

**4.2.3 Hinge Plate:** The allowable design values of Hinge Truss Plate Connectors in shear, tension and compression are shown in Table 3. Imposed forces at the joint and within the truss containing the joint must be determined using a structural model with a pin at the hinge joint location. Allowable design values are applicable when the

connection is made with a 1-inch (25.4 mm), or smaller, gap between the two wood members at the connection. The design load due to combined shear and axial loads must not exceed the allowable load using the Hankinson formula as follows:

$$F_{\theta} \leq P_{\theta}$$

where:

$F_{\theta}$  = Imposed combined shear and axial load,  
lb =  $(F_a^2 + F_v^2)^{0.5}$

$P_{\theta}$  = Allowable combined shear and axial load,  
lb =  $(P_a \times P_v) / ((P_a \times (\sin \theta)^2) + (P_v \times (\cos \theta)^2))$ .

$F_a$  = Imposed axial force, lb.

$F_v$  = Imposed shear force, lb.

$P_a$  = Allowable axial force, lb. (In compression or tension corresponding to imposed axial force).

$P_v$  = allowable shear load, lb.

$\theta$  (theta) = angle between  $F_{\theta}$  and the length of the plate.

## 5.0 CONDITIONS OF USE

The Alpine Truss Plates (Metal Connector Plates) described in this report comply with, or are suitable alternatives to what is specified in, those codes listed in Section 1.0 of this report, subject to the following conditions:

- 5.1** This evaluation report and the installation instructions, when required by the code official, must be submitted at the time of permit application. In the event of a conflict between the manufacturer's published installation instructions and this report, this report governs.
- 5.2** Each application for a building permit using these truss plate connectors must be accompanied by calculations, details and other documentation showing that the design, manufacture, and proposed installation conforms with the requirements of the applicable code. The calculations must be prepared by a registered design professional where required by the statutes of the jurisdiction in which the project is to be constructed.
- 5.3** This report establishes plate design values only. For items not covered by this report, such as truss design, fabrication, quality assurance and inspection, refer to ANSI/TPI 1, engineering drawings and the applicable code.
- 5.4** The design values (lateral resistance values, effective tension strength ratios, and effective shear resistance ratios) used in the design of trusses using Wave, H and SS metal truss connector plates must not exceed those listed in Tables 1 and 2. The shear resistance ratios used in the design of trusses using Trulox Truss Plate Connectors must not exceed those listed in Table 2. The shear, tension and compression loads used in the design of trusses using Hinge Truss Plate Connector must not exceed those listed in Table 3. Load combination reductions must be in accordance with the applicable code.
- 5.5** All lumber used in the fabrication of trusses using Alpine Truss Plate Connectors must be graded in compliance with the applicable building code and must have a moisture content not to exceed 19 percent at the time of assembly. Wet service factors from ANSI/TPI 1 Section 6.4.6 must be applied to the table values when the lumber moisture

content exceeds 19 percent. Allowable loads shown in the tables of this report are not applicable to metal connector plates embedded in either fire-retardant-treated lumber or preservative-treated lumber.

- 5.6 Metal truss connector plates and hinge plates must be installed in pairs on opposite faces of truss members.
- 5.7 Galvanized G60 and G90 metal truss plate connectors subject to corrosive environments must be protected in accordance with Section 6.5 of ANSI/TPI 1.

**Note: Conditions 5.8 through 5.13 apply to Hinge Plate metal connectors only:**

- 5.8 Allowable load values for the Hinge Plates are applicable to hinge plate pairs installed on opposite faces and positioned in the 180-degree (unbent) position in the final installation of the truss.
- 5.9 The allowable compression load given in Table 3 is valid for applications where sheathing is attached to the truss chord members containing the metal hinge plates, and lateral translation across the joint is inhibited by the sheathing being installed continuously across the joint as prescribed by code or by other means acceptable to the code official. Hinge plate connectors must not be used to transfer any loads in a direction perpendicular to the plane of the truss, such as for design of load transfer at joints of unblocked diaphragms.
- 5.10 Due to the rotation provided at the joint of the Hinge Plates, the truss design must be modeled with a pin at the hinge joint location. In the final installed condition, shear loads must be applied within the plane of the hinge plate, at a 90-degree angle to the long axis.
- 5.11 Design of diaphragms with trusses manufactured with the Hinge Plate is outside the scope of this report.
- 5.12 Allowable design values given in Table 3 for Hinge Plate connectors are applicable when the connection is made with a 1-inch (25.4 mm), or smaller, gap between the two wood members at the connection. No adjustments for load duration are permitted.

- 5.13 Use of the Hinge Plate is limited to prefabricated trusses. Field installation is prohibited. Compliance with IBC Section 2303.4 or IRC Sections R502.11 and R802.10, as applicable, is required.

## 6.0 EVIDENCE SUBMITTED

- 6.1 Data in accordance with the National Design Standard for Metal Plate Connected Wood Truss Construction, ANSI/TPI 1 for Alpine Wave; H and SS; and Trulox metal truss plate connectors.
- 6.2 Engineering summary of plate properties, table of design values, prepared by Alpine Engineered Products, Inc. (now ITW Building Components Group, Inc.), signed, sealed and dated September 17, 1999.
- 6.3 Manufacturer's descriptive literature.
- 6.4 Data in accordance with the ICC-ES Acceptance Criteria for Metal Hinge Plate Connectors for Wood Trusses (AC283), approved November 2015 (editorially revised April 2018) for Alpine hinge plate metal connectors.

## 7.0 IDENTIFICATION

- 7.1 See Figures 1 through 4 for identifying patterns. Wave Plates™ are identified by the unique double-offset slot pattern. H and SS plates are identified by the embossed symbol "Alpine" and either "H20" or "S18" for the H and SS plates, respectively. Hinge plates are identified by the grommetted hinge and the symbols "Alpine" or "HP28W." Each shipping container of Alpine Truss Plate Connectors is marked with the ITW Building Components Group Inc. name and/or trademark, and the evaluation report number (ESR-1118).
- 7.2 The report holder's contact information is the following:

**ITW BUILDING COMPONENTS GROUP INC.**  
**13825 WEST BUSINESS CENTER DRIVE, UNIT A**  
**LAKE FOREST, ILLINOIS 60045**  
**(800) 326-4102**  
[www.alpineitw.com](http://www.alpineitw.com)

**TABLE 1—WAVE PLATE™, H and SS PLATES  
ALLOWABLE LATERAL RESISTANCE VALUES (lb/in<sup>2</sup>/PLATE)<sup>1</sup>**

ITW BCG PLATE	TPI AREA BASIS	LUMBER <sup>2</sup>	HYDRAULIC-PLATEN EMBEDMENT VALUES <sup>3</sup>				SINGLE-PASS ROLLER EMBEDMENT VALUES <sup>3</sup>			
			AA	EA	AE	EE	AA	EA	AE	EE
WAVE	GROSS AREA (0" end & 0" edge distances)	S. Pine	206	158	163	170	179	143	142	153
		Doug. Fir-Larch	206	156	145	153	179	141	126	138
		Hem-Fir	164	109	106	124	134	96.7	86.5	110
		SPF	159	109	106	118	130	96.7	86.5	105
	NET AREA ( <sup>1</sup> / <sub>2</sub> " end & 0" edge distances)	S. Pine	275	195	163	170	239	177	142	153
		Doug. Fir-Larch	275	195	145	153	239	177	126	138
		Hem-Fir	208	134	106	124	170	119	86.5	110
		SPF	208	130	106	118	170	115	86.5	105
H <sup>4</sup>	NET AREA ( <sup>7</sup> / <sub>16</sub> " or <sup>11</sup> / <sub>32</sub> " end & 0" edge distances)	S. Pine	197	128	122	123	147	116	91	112
		Doug. Fir-Larch	197	128	120	115	147	116	89	104
		Hem-Fir	143	84.7	82.5	92.7	117	81.2	67.1	88.9
		SPF	141	84.1	81.6	92.7	114	80.7	66.4	88.9
SS <sup>4</sup>	NET AREA ( <sup>7</sup> / <sub>16</sub> " or <sup>11</sup> / <sub>32</sub> " end & 0" edge distances)	S. Pine	236	173	156	136	182	133	120	105
		Doug. Fir-Larch	236	173	156	136	182	133	120	105
		Hem-Fir	161	127	117	112	126	99	91	87
		SPF	161	127	117	112	126	99	91	87

For **SI**: 1 psi = 6.9 kPa.

<sup>1</sup>Values given in Table 1 are allowable lateral resistances of the metal connector plate teeth, expressed in pounds per square inch of plate for a single plate (double for plates on both faces when applying to area on only one face). To achieve values, plates must be installed on opposite sides of joint.

<sup>2</sup>Values given in Table 1 are based on the following assigned specific gravities for the lumber species combinations listed: S. Pine G = 0.55, Doug fir-larch G = 0.50, hem-fir G = 0.43, SPF G = 0.42.

<sup>3</sup>Plate orientation designations:

- AA = Plate slots parallel to load, wood grain parallel to load.
- EA = Plate slots perpendicular to load, wood grain parallel to load.
- AE = Plate slots parallel to load, wood grain perpendicular to load.
- EE = Plate slots perpendicular to load, wood grain perpendicular to load.

<sup>4</sup>ITW BCG H and SS plates: an end distance of <sup>7</sup>/<sub>16</sub> inch applies for the AA orientation, and an end distance of <sup>11</sup>/<sub>32</sub> inch applies for the EA orientation.

**TABLE 2—WAVE PLATE™, H, SS AND TRULOX PLATES  
EFFECTIVE TENSION AND SHEAR RESISTANCE ALLOWABLE DESIGN VALUES**

PROPERTY & FORCE DIRECTION	WAVE PLATE™		H PLATE		SS PLATE		TRULOX PLATE	
	Effic'y Ratio	pli/pair of Plates	Effic'y Ratio	pli/pair of Plates	Effic'y Ratio	pli/pair of Plates	Effic'y Ratio	Pli/pair of Plates
Tension @ 0°	0.512	895	0.710	1784	0.735	2444	-	-
Tension @ 30°	-	-	-	-	0.411	1367	-	-
Tension @ 60°	-	-	-	-	0.289	961	-	-
Tension @ 90°	0.486	849	0.300	754	0.269	894	-	-
Shear @ 0°	0.563	656	0.435	656	0.568	1133	0.711	829
Shear @ 30°	0.739	861	0.720	1086	0.752	1500	0.632	737
Shear @ 60°	0.832	969	0.810	1223	0.941	1877	0.708	825
Shear @ 90°	0.487	567	0.517	780	0.642	1281	0.665	775
Shear @ 120°	0.454	529	0.330	498	0.515	1027	0.227	265
Shear @ 150°	0.477	556	0.412	622	0.418	834	0.147	171

For **SI**: 1 lb/inch = 0.175 N/mm, 1 inch = 25.4 mm.

TABLE 3—HINGE PLATE ALLOWABLE DESIGN VALUES<sup>1,2,3</sup>

PROPERTY	ALLOWABLE DESIGN VALUE (lb)
Shear	566
Tension	810
Compression	810

For SI: 1 lb = 4.448 N.

<sup>1</sup>Design values determined using SPF lumber.

<sup>2</sup>Tabulated design values must not be increased by any load duration factor.

<sup>3</sup>Allowable design values are applicable to application of the metal plates installed in pairs to truss chord members.

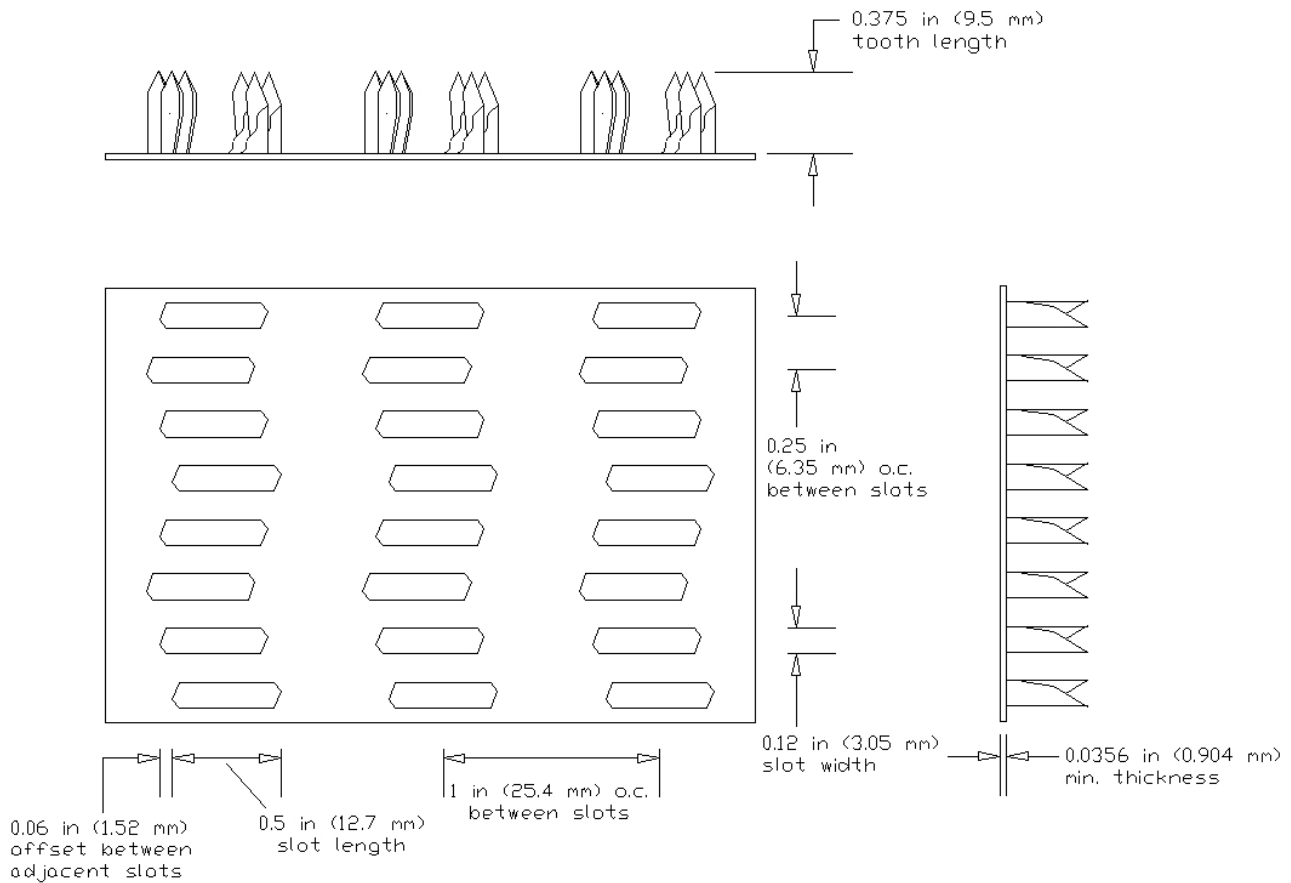
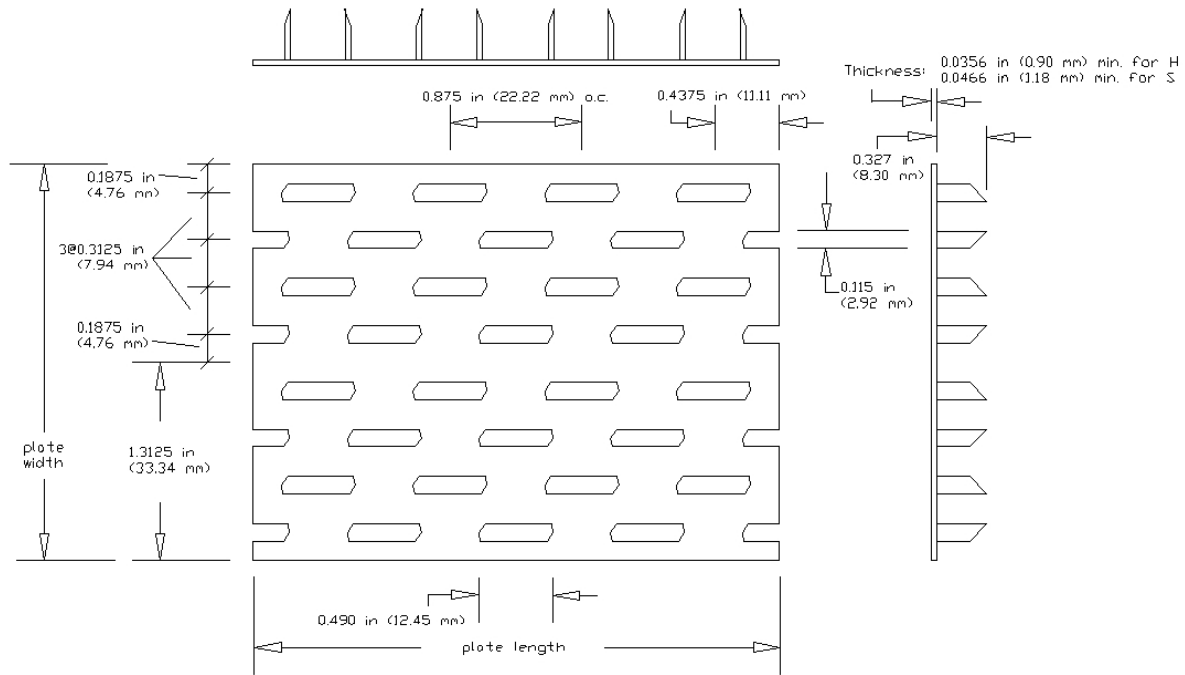

PLATE AVAILABLE IN INCREMENTS OF 1 IN (25.4 mm).  
 PLATE SHOWN ABOVE IS A 2X3 (2 IN X 3 IN, 50.8 mm X 76.2 mm).

FIGURE 1—WAVE PLATE



The H and SS plates are available in width increments of  $1\frac{5}{16}$  inch (33.3 mm) and length increments of  $1\frac{3}{4}$  inches (44.4 mm). This drawing shows size H0203 or S0203 ( $2\frac{5}{8} \times 3\frac{1}{2}$  inches) (67 x 89 mm).

FIGURE 2—H AND SS PLATES

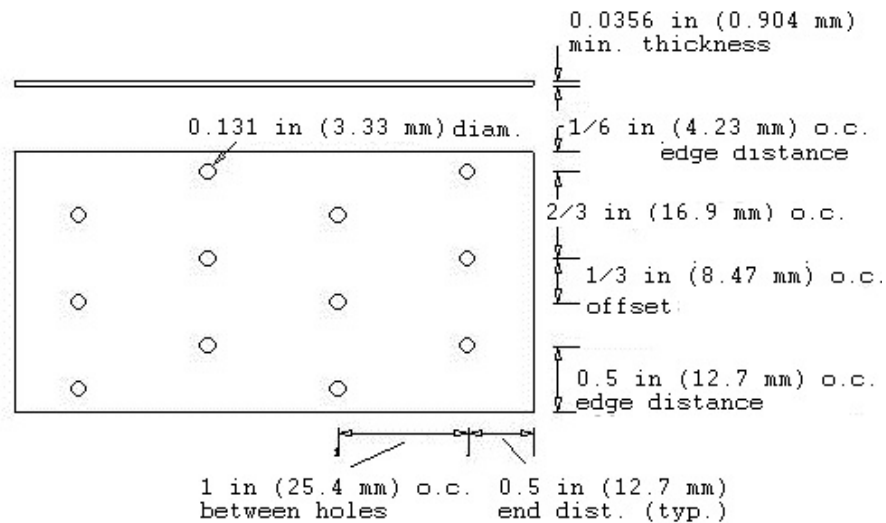

PLATE AVAILABLE IN INCREMENTS OF 1 IN (25.4 MM).  
 PLATE SHOWN ABOVE IS A 2X4 (2 IN. X 4 IN., 51 mm X 101 mm).

FIGURE 3—TRULOX PLATE

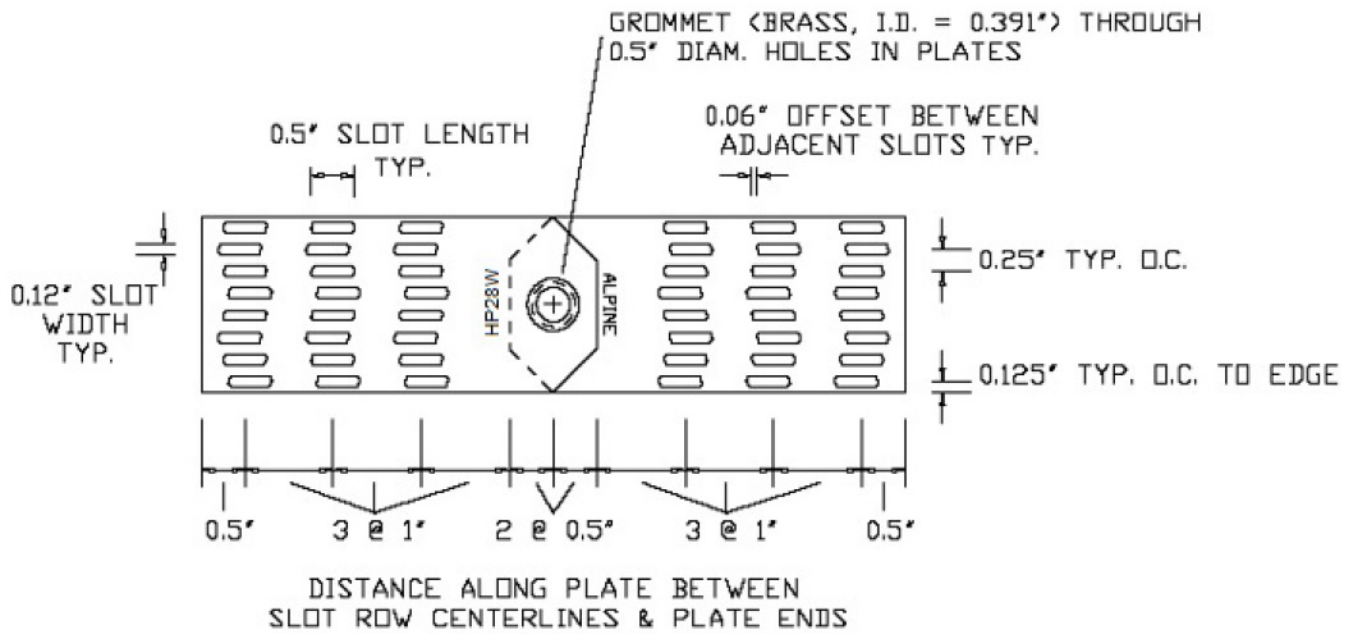

FIGURE 4—HINGE PLATE